

**SERVICE MANUAL MODEL 217-A
FROSTY FACTORY OF AMERICA INC.
RUSTON, LA. 71270
(318) 255-1162**

All technical data, pictures and drawings contained in this manual are not binding on the manufacturer nor can the manufacturer be held liable for any modifications to the machine in whole or in part.

Rev. 03/07/03 pt.

SECTION 1

INTRODUCTION

1.1 USE OF THIS MANUAL

Your service manual has been prepared as a guide to help you get the most from your Petite Sorbeteer. It contains information about the installation and operation of your machine. The manual also contains instructions for service and care. The manual should be read carefully by the operator of the Petite Sorbeteer to become familiar with the machine and the correct operating procedures described within. The following notations are used throughout the manual to bring important facts to your attention:

- “**Warning**” - This notation is used whenever the personal safety of the operator(s) might be jeopardized, if procedures are not followed correctly.
- “**Caution**” - This notation is used whenever the machine or related equipment may receive or cause damage if not observed.
- “**Note**” - This notation is used to bring important information to your attention that will enhance the performance of your machine.

1.2 PRELIMINARY INSPECTION

Unpack the unit as soon as possible upon its arrival. Check the entire machine and its contents for possible shipping damage. Note damage, if any, and notify your carrier immediately. Frosty Factory of America cannot be responsible for damaged merchandise caused by shipping. Inventory the accessories to be sure they include the items you specified on your order. Normally the accessories include:

- ___ Beater Bars (2)
- ___ Drip Trays (2)
- ___ Faceplate Knobs
- ___ Faceplates (2)
- ___ Hopper Covers (2)
- ___ Petro-Gel
- ___ Sanitizer
- ___ Spare Faucet O-Rings
- ___ Warranty Card
- ___ Wire Brush

1.3 DESCRIPTION

The Petite Sorbeteer is manufactured with a high quality stainless steel cabinet which houses two restaurant grade stainless steel hoppers and cylinders which are attached to a sturdy, hand-crafted steel frame. The hopper and cylinder are joined by a feed hole to allow gravity flow operation. The drive motor is mounted within the frame and rotates counter clockwise (as viewed from the front of the machine). Panels are stainless steel with plastic louvered inserts to allow maximum airflow for cooling. A stainless steel beater assembly is installed in each cylinder and held in place by a clear plastic faceplate, which in turn is held onto the face of the machine with four attractive knobs. Four adjustable legs are installed for leveling. Mix dispensing is provided for via a specially designed “drip-free”, automatic closing faucet assembly.

1.4 SPECIFICATIONS

Freezing Cylinder

Two, 3.5 quart (3.3 liter) capacity.

Electrical

Standard is 115V/60Hz/1Ph. 14.0 total amps
With a 20 amp cord.

Optional is 230V/60Hz/1Ph. 7.0 total amps
with a 20 amp cord.

Mix Hopper

Two, 12.0 quart (11.5 liter) capacity.

Dimensions

Width: 22” (53 cm)

Depth: 19.5” (50 cm)

Height: 24.5” (62 cm)

Floor Clearance: 4” (10 cm)

Refrigeration Unit

Internally mounted condensing unit.

Compressor: ¾ HP.6600 BTU/Hr.

Refrigerant: R404

Suction Pressure: 35 psi with both
cylinders operating. 20 psi with one
cylinder operating.

Approximate Weights

Net: 165 lbs. (75 kilos)

Crated: 175 lbs. (80 kilos)

Volume: 9.0 cu. Ft.

Beater Motor

Two, 1/12 hp. Motor

* Specifications subject to change without notice.

This unit is designed and constructed to meet stringent safety and sanitation requirements.

SECTION 2
LOCATION & INSTALLATION

2.1 SAFETY PRECAUTIONS

Do not attempt to operate your Petite Sorbeteer until the safety precautions and operating instructions in this manual are read completely and are thoroughly understood.

Take notice of all warning labels on your Petite Sorbeteer. The labels have been put there to inform and protect persons operating and servicing your equipment. Care must be taken not to damage or destroy labels during installation and servicing. The labels have been designed to withstand routine cleaning and handling. Damaged or missing labels should be promptly replaced with approved labels from Frosty Factory of America Inc

2.2 INSTALLATION

Placing your Petite Sorbeteer in a highly visible area will enhance sales. A suitable station will be able to support 200 pounds and will have a dedicated electrical outlet.

CAUTION: Do not attempt to share the dedicated electrical outlet with any other appliance, this will cause the circuit breaker to trip.

1. Uncrate your Petite Sorbeteer.
2. The Petite Sorbeteer must be placed on a sturdy platform able to hold the weight of the machine when full of product. Level the machine by turning the adjustable part of the leg. The machine must be level front to back as well as left to right.
3. Petite Sorbeteers equipped with air-cooled condensers must have **correct ventilation**. Air intake is at the rear of the Petite Sorbeteer and discharge through the side; both require 8” clearance. All Petite Sorbeteers require 6” at the top.

NOTE: Locating the unit in direct sunlight, near cooking facilities or any high heat area will reduce the performance of your machine.

CAUTION: Extended operations under severe heat condition can damage the cooling system.

NOTE: Any establishment serving beverages from frozen drink machines is responsible for providing the necessary facilities for cleaning and sanitizing their food service equipment.

4. Place the three-position switch in the OFF position (center).
5. Connect the power cord. The Petite Sorbeteer must be connected to a properly grounded receptacle. The electrical cord furnished as part of the Petite Sorbeteer has a three prong grounding type plug. The use of an extension cord is not recommended. If one must be used, refer to the national and local electrical codes. **Do not** use an adapter to get around grounding requirements.

WARNING: Do not attempt to alter the electrical plug. Serious injury or electrocution may result.

6. Install the drip trays, hopper covers, and faceplates and beater bar assemblies on the Petite Sorbeteer.

SECTION 3 OPERATION

3.1 MACHINE CONTROLS

Two selector switches located on the front of the machine control operation of the Petite Sorbeteer. Selection of the right (snowflake) position with the upper (three-position) switch as well as the lower (two-position) switch will schedule the machine for normal operation. The compressor cycle is protected by a time delay circuit, which will engage the compressor approximately 2 minutes after normal operation is initiated. The red fill light located above the switches will illuminate when the level of mix is low in the hopper. A thermostat knob is visible on the electrical control box of your machine. This is set at the factory and should not be changed except by an authorized service repairman.

Refer to the chart below for functions available with various combinations of switch positions.

Normal Operation - Machine will freeze mix to provide frozen beverage as desired.

Cooling Operation - Machine will automatically come on whenever necessary to keep mix cooled to 5° C/40° F - used primarily for overnight storage of mix remaining in the machine.

Cleaning Operation - The drive motor will run in the faucet position to allow a stirring action of the rinse water while cleaning.

Off - The hand symbol is the recognized international symbol for “stop”. In this position, the machine will not run.

3.2 THE PRODUCT YOU SERVE

The Petite Sorbeteer will produce a fine grain, semi-frozen slush when the proper mix is used. When measured with a refractometer, the proper mix will measure 12 to 18 “Brix”. Too little sugar in the mix will cause larger ice crystals to form. Too much sugar will lengthen the freeze time.

CAUTION: Any attempt to freeze water only will cause severe damage to your machine.

NOTE: Do not add sugar directly into the machine, as some of it will settle and result in an improper mix.

FRUIT JUICES with at least **32 grams of sugar per 8 oz. serving** will freeze well in the Petite Sorbeteer. They will remain stable during the freezing process while retaining their natural color and flavor.

NEUTRAL BASES are used to produce a neutral frozen cocktail base. A wide variety of different drinks can be created from one neutral base by the addition of various flavors. Most brands of neutral bases specify a mixture of four parts water to one part neutral base. However, before use in the Petite Sorbeteer, be sure the “Brix” level is 12 to 18.

The amount of **ALCOHOL** in the recipe will affect the freezing process. As a rule of thumb, for the mix to freeze properly, the recipe should contain no more than 25 percent alcohol.

Suggestion for optimum production and sales:

- 1) Use the finest ingredients available.
- 2) Test the product before serving it.
- 3) Keep the machine clean - **ALWAYS!**

3.3 PRODUCT CONSISTENCY

An exclusive patented torque sensing mechanism developed by Frosty Factory of America will produce consistent texture and thickness of your frozen beverages. The adjustment screw (accessible through each side panel) is pre-set at the factory. Various mix consistencies can be achieved by turning the screw clockwise (thicker drink) or counter clockwise (thinner drink). Turn the screw one full turn then allow enough time to lapse (about three minutes) for the compressor to complete a cycle before sampling. Continue this process until desired result is obtained.

3.4 START UP

NOTE: Before start-up, be sure the machine has been sanitized in accordance with procedures set forth in section 4 of this manual.

Pour the mix into the hopper and allow it to drain into the cylinder. When the hopper and cylinder are full (normally about one inch from the top of the hopper) the machine is ready to run. Turn on by selecting the “right” (snowflake) position of both switches on the front panel.

NOTE: Add mix as soon as the red light comes on to prevent air from entering the cylinder.

CAUTION: Allowing air into the cylinder will cause a gentle rocking motion of the machine. If the mix is not yet frozen the air will escape by turning the machine off for 20-30 seconds.

NOTE: Pre-cooling the mix will reduce freeze-time, example: mix poured in at 40° F will freeze in half the time of mix at 80° F.

WARNING: NEVER under any circumstances, place your finger or any other object into the hopper or feed hole while the machine is in operation. Serious personal injury may occur.

3.5 FREEZE TIME

The freeze time on the model 217 is approximately 25 minutes with both cylinders operating. These figures are based on **ideal conditions** with a starting mix temperature of approximately 40 degrees. The time will increase if the machine is not properly ventilated or is operated in a hot environment. Some recipes with high alcohol or high sugar content will naturally take a little longer.

SECTION 4 MAINTENANCE

4.1 CLEANING

The following cleaning procedure should be used for initial start-up and on an as needed basis to comply with the minimum cleaning and sanitizing frequencies specified by the Federal, state or local regulatory agency having jurisdiction.

- (1) Turn the machine to the off, “hand” position. Remove hopper cover. Look in the hopper to locate and remove the float and float clip for cleaning.
- (2) If applicable, drain mix into a sanitized container as per local health code procedures. Store in an adequate cooling facility.

NOTE: Do not put hands or foreign matter into mix.

- (3) Pour two gallons of cool (75° F.) water into the hopper. Clean the hopper and feed hole. Place upper switch in “faucet” position to let the machine stir for 2 minutes. Turn machine “OFF”, drain and dispose of the rinse water. Repeat until water is clear.
- (4) Mix two gallons of warm water (approximately 100° F) with two ounces of sanitizing powder to achieve 100 parts per million (PPM) sanitizing solution.
- (5) Pour the sanitizing solution into the hopper. Clean hopper and feed hole. Place upper switch in “faucet” position. Let solution stir for 5 minutes. Then, turn machine “OFF” and drain the solution. Rinse with fresh water and drain.
- (6) Remove the knobs from the faceplate by turning in a counter clockwise direction. Carefully pull the faceplate straight away from the front of the machine. Remove the beater bar assembly from the cylinder. Then slide the spring seal off the rear of the beater bar. Unscrew white faucet cap to remove faucet plunger from faucet body. Remove all o-rings for cleaning.

NOTE: Do not unscrew faucet body from faceplate to clean. (Leak free service after disturbing the Teflon seal cannot be assured).

- (7) All parts removed during the above steps plus the drip tray and insert can now be cleaned in your warm (100° F) sanitized solution. Rinse all parts in clean rinse water and allow to air dry before re-assembly.
- (8) Repeat procedure for units with two freezing cylinders.

4.2 RE-ASSEMBLY

- (1) Using Petro-Gel (or other sanitary food grade lubricant), lightly lubricate the longer end of the beater shaft. Slide beater seal onto the shaft with the spring end toward the beater bar. (Refer to diagram on top of the hopper cover for correct installation of spring seal)

NOTE: The black carbon ring must be facing the end of the beater bar so it will be in direct contact with the white ceramic seal inside the cylinder when the beater bar is re-installed. **This is a dry seal and must be kept free of lubricants.**

CAUTION: Lube the beater bar shaft. The beater seal may become damaged if the beater shaft is not lubricated before installation of the beater seal.

- (2) Carefully insert the beater bar (with beater seal) into hole at the rear of the cylinder and rotate until it fully engages into the drive plate.

CAUTION: Rough handling during beater bar installation can damage the ceramic seal.

- (3) Lubricate the large, black, rubber, faceplate O-ring with Petro-Gel then re-install and press firmly into the faceplate groove for proper fit. Re-install o-rings on faucet

- (4) Re-install the faceplate on the machine. First place the faceplate bushing onto the beater shaft. Then slide face plate onto the four studs. Now re-attach the faceplate knobs and tighten evenly until the faceplate O-ring is snug against the cylinder. Re-install float and float clip.

CAUTION: If you over tighten the knobs or tighten against a beater bar that is not fully engaged in the drive plate permanent distortion to the faceplate may occur!

- (5) Mix two gallons of warm water with one 2 oz. Packet of Sanitizer.
- (6) Pour two gallons of solution into hopper. Clean the hopper and feed hole with a clean sanitized brush.
- (7) Place upper switch in “faucet” position. Let solution stir for 5 minutes. Turn upper switch “OFF” (hand) position, **drain all solution**.
- (8) Pour product into hopper. Replace hopper cover. Place both switches in right (snowflake) position when ready to freeze product.

4.3 PREVENTATIVE MAINTENANCE

It is recommended that a maintenance schedule be followed to keep the machine clean and operating properly.

WARNING: Never attempt to repair or perform maintenance on machine until the main electrical power has been disconnected.

A. DAILY

The exterior of the machine should be kept clean at all times to preserve the luster of the stainless steel. A mild soap is recommended. Use a soft cloth or sponge to apply the cleaner.

B. WEEKLY

- (1) Check O-rings and rear seal for excessive wear and replace if necessary.
- (2) Clean the drip tray and front of the freezer with a soap solution.

C. MONTHLY

CAUTION: Air-cooled condensers must have proper air circulation. Failure to clean the condenser on a regular basis may result in serious damage and could void warranty.

- (1) Visually inspect the condenser for dirt by shining a light through the coil from the inside of the condenser.
- (2) If the condenser is dirty, place a wet towel over the inside of the condenser.
- (3) Using compressed air or a CO2 tank, blow out the dirt from the outside of the condenser. Most of the dirt will cling to the wet towel.
- (4) An alternative method of cleaning the condenser is to use a condenser brush and vacuum.

NOTE: If the condenser is not kept clean, loss of refrigeration efficiency will result, causing extended run time or soft product consistency.

4.4 EXTENDED STORAGE

Refer to the following steps for storage of the machine over any long shutdown period.

- (1) Turn the three position switch to the OFF (center) position.
- (2) Disconnect (unplug) from the electrical supply source.
- (3) Clean thoroughly with a warm detergent all parts that come in contact with the mix. Rinse in clean water and dry all parts. Do not sanitize. Petite Sorbeteer parts can be left disassembled until ready for use.

NOTE: Do not let the cleaning solution stand in the hopper or in the cylinder during the shutdown period.

4.5 TROUBLESHOOTING

1. Machine does not run when turned on.

- A. Be sure that the plug is properly installed in wall outlet.
 - B. Check and reset circuit breaker if necessary.
 - C. Be sure that no other appliances are sharing the circuit.
 - D. If problem remains, call service repairman.
- 2. Beater motor starts but compressor doesn't.**
- A. Both switches must be in the right (Snowflake) position.
 - B. Allow approximately one or two minutes for time delay to respond.
 - C. Check that the machine has been properly leveled.
 - D. If problem causes circuit breaker to trip, call service repairman.
- 3. Mix dripping from drip tube.**
- A. Spring seal on beater bar is dirty or improperly installed. Remove, clean and re-install spring seal assembly according to instructions and diagram on top of the hopper cover.
 - B. Ceramic seal (inside the freezing cylinder) is dirty or loose. Clean ceramic seal. If loose re-install as necessary. Also check that the carbon ring on the seal is not chipped, cracked, dirty or greasy. Replace seal if necessary.
- 4. Unit runs but product does not freeze to desired consistency.**
- A. Check recipe for proper amount of sugar.
 - B. Check tension of TCC screw, if necessary turn clockwise to increase thickness of drink.
 - C. Check unit placement for adequate ventilation. (At least 8" clearance required on all sides except for water-cooled units.)
 - D. Check the condenser to see if it has become clogged with lint, dust etc.
 - E. If product freezes too much, be sure that the cylinder is full of mix.
 - F. If problem remains, call service repairman.
- 5. Fill light is on when hopper is full of product.**
- A. Remove and re-install float with two dots facing up.
 - B. If float is stuck, clean float and stem and re-assemble.
- 6. No product comes out when faucet handle is pulled while unit is running.**
- A. Frozen product is blocking "feed hole". **Turn machine off** then clear ice plug from feed hole.
WARNING: Never place fingers in the "feed hole" as serious personal injury may occur.
 - B. Mix is frozen solid. Low sugar content, product separation or cylinder not full.
- 7. Compressor starts and stops intermittently.**
- A. If unit is air-cooled check to see that the fan is turning freely.
 - B. If unit is water-cooled be sure that the water is turned on and flowing.
 - C. If the on/off time is 30 seconds or longer, this is normal if product is frozen and no product has been pulled in a while.
 - D. If the problem is causing the breaker to trip, call service repairman.
- 8. Unit continues to run when switched to stand-by**
- A. Have qualified technician remove back panel and reset thermostat. (turn all the way off then turn all the way on again.)
 - B. If problem remains call service repairman.
- 9. Beater bar does not turn**
- A. Mix is frozen solid. See item 6-B.
 - B. Drive coupling stripped. Call service repairman.
 - C. Faulty motor. Call service repairman.

REAR CYLINDER AND DRIVE ASSEMBLY PARTS LIST
Models 113, 117, 217, 513, 527

1 2 3 4 5 6 7 8 9

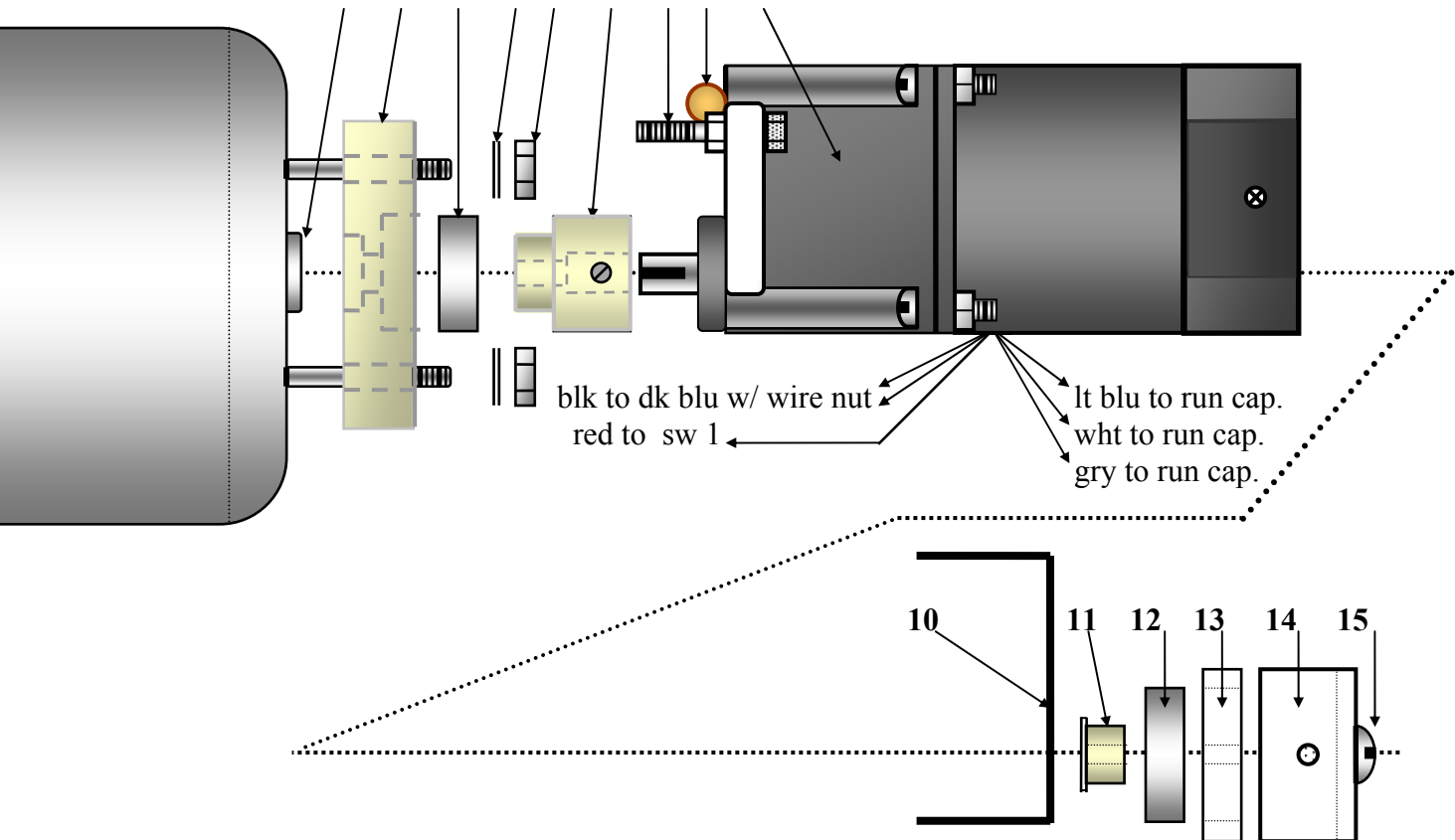

DESCRIPTION	PART NUMBER
1. Ceramic Seal*	F0355*
2. Bearing Spacer Block	C2316B
3. Front Motor Bearing	F0267
4. Flat Washer	F0443 (5/16")
5. Nut	F0439 (5/16"x18)
6. Drive Coupling	C0906
7. Stop Bolt Assembly	F0435 (1/4"20x11/4")
8. Mercury Switch	F0209
9. Drive Motor 115V	F0409
Drive Motor 230V	F0415
10. C-Bracket	F1206
11. C-Bracket Stub	C1207
12. Rear Support Bearing	F0479
13. Rear Bearing Carrier	C1216B
14. Rear Cross Brace	F1221 (F5578 for models 217&527)
15. Frame Screw	F0237

*F0355 is the part number for the Spring Seal Assembly

Torque Consistency Control
Model 117W

1 2 3 4 5 6 7 8 9 10 11 12

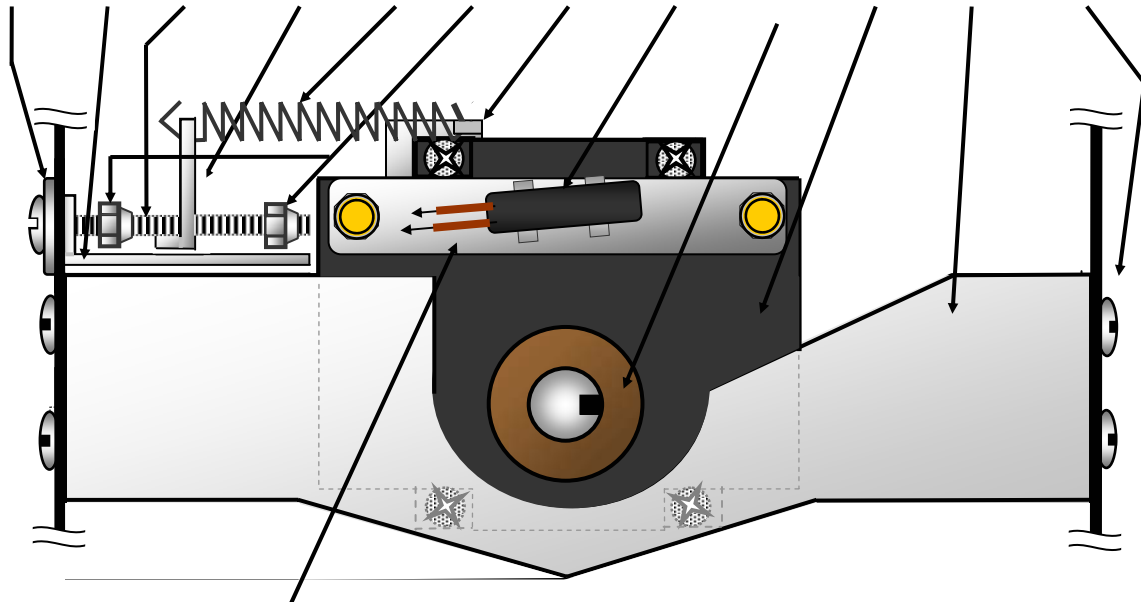

Wires to control circuit

ITEM NUMBER	DESCRIPTION
1. F0443	Washer, Flat 5/16"
2. F1238	Spring Adjustment Carrier
3. F0440	Tension Adj.Screw 1/4"x20x3"
4. F1225	Motor Adjustment Bracket
5. F0432	Tension Spring
6. F0438	Lock Nut 1/4"x20 (2 each)
7. F1239	Motor Spring Bracket
8. F0752	Mercury Switch Assembly
9. C0906	Drive Coupling
10. F0409	Drive Motor(115V)
-- F0415	Drive Motor(230V)
11. F1219	Front Cross Brace
12. F0237	Frame Screw(5/16x18x1/2)

Note: Items numbered 9 through 12 are not part of the torque consistency control system, but are listed for user convenience.

**Model 217A
Wire Diagram**

Box layout

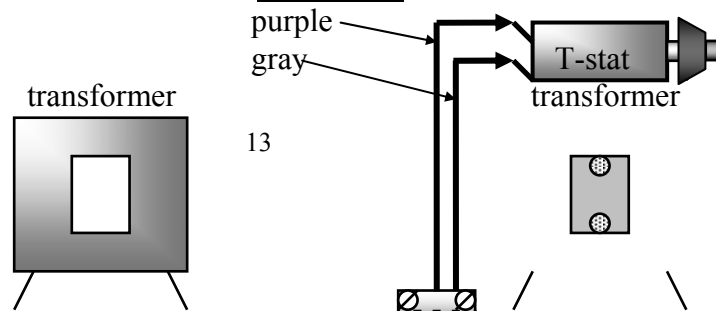

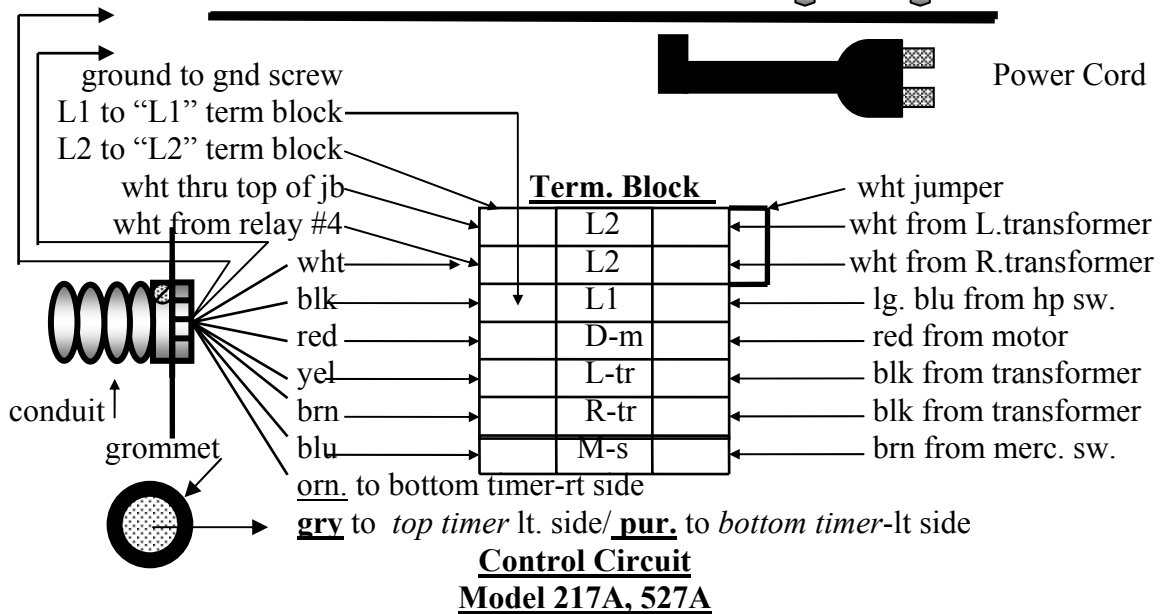
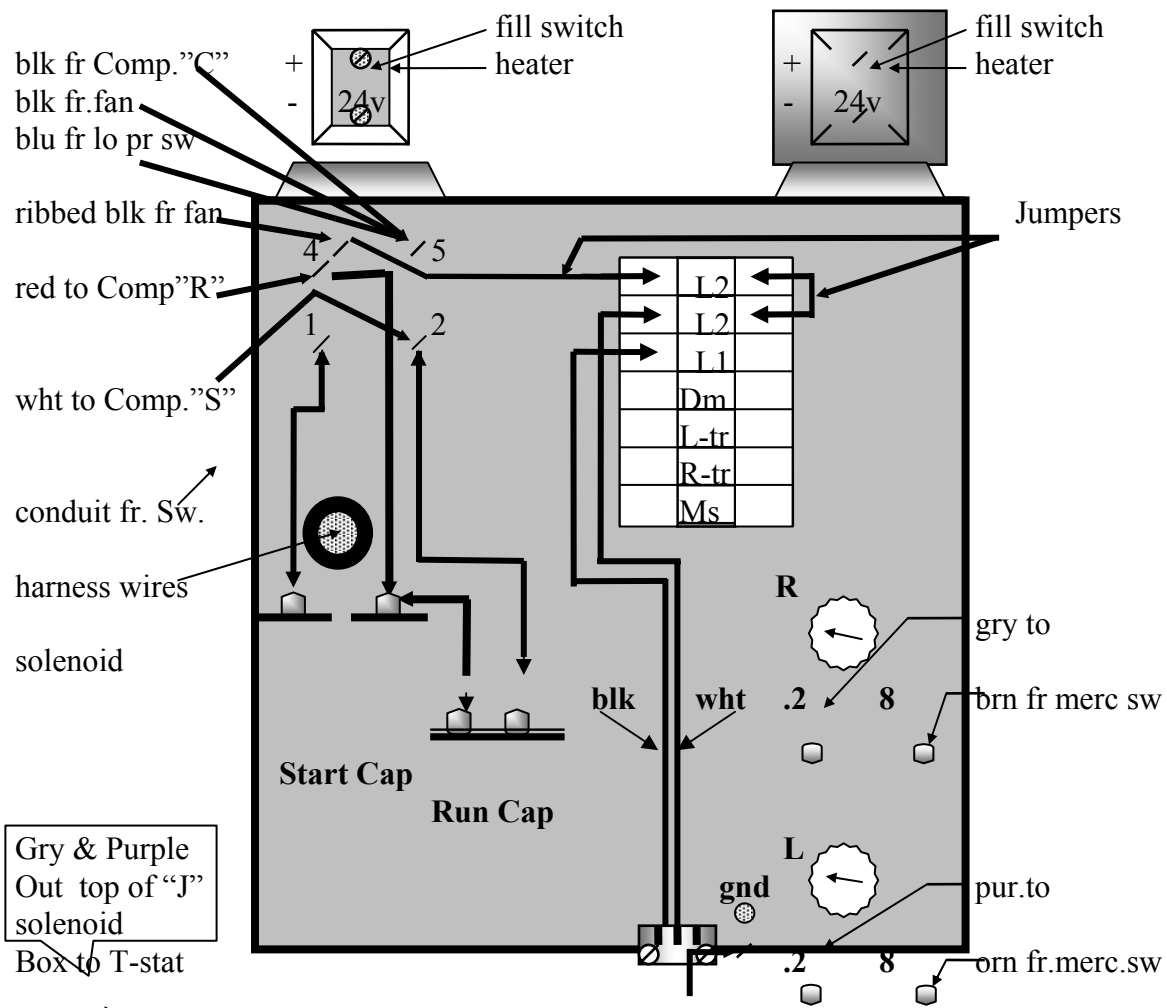

➔ To Compressor Relay

Delay Timer

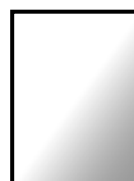

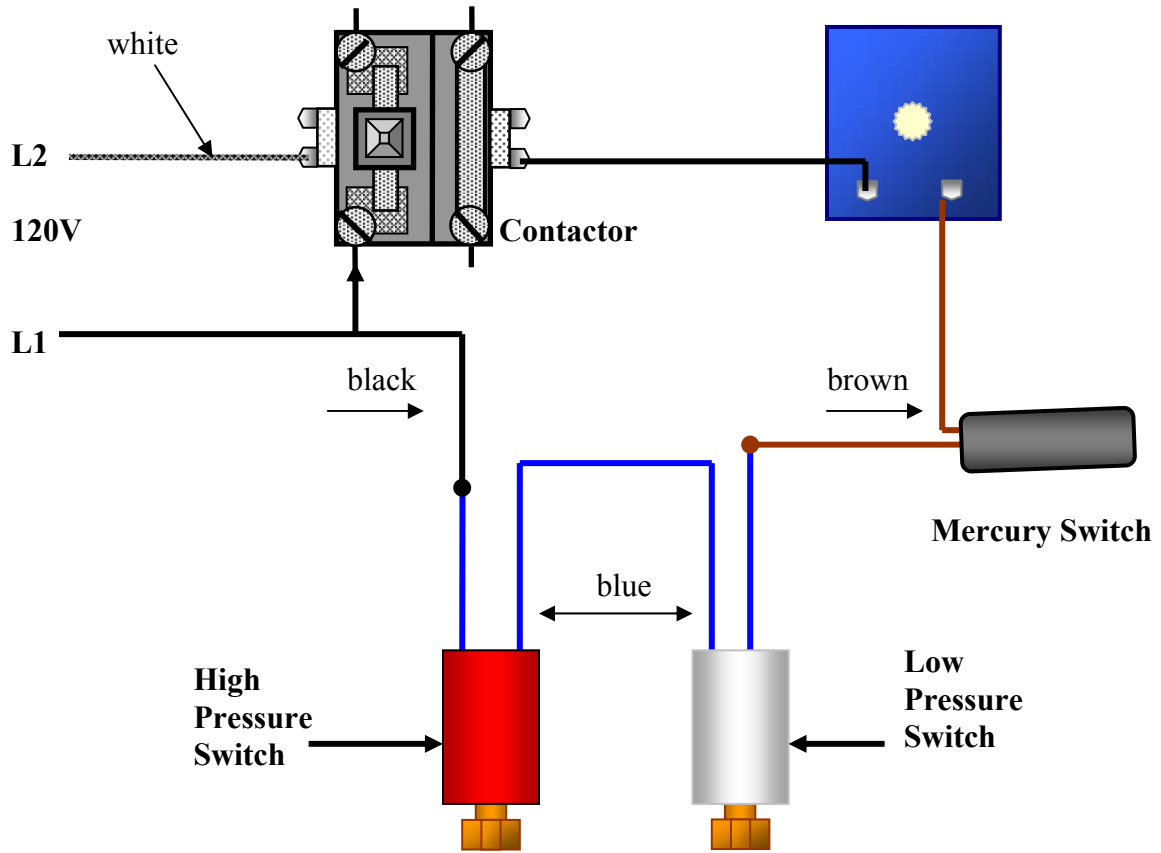

Face Plate/Faucet Assembly

Face Plate/Faucet Assembly

A. The face plate assembly

- | | |
|--------------------|-------|
| 1. Bushing | C6520 |
| 2. O-Ring | F0374 |
| 3. Faucet assembly | C6513 |

B. The faucet assembly.

- | | |
|--------------------------|--------|
| 1. Faucet body. | C6513B |
| 2. Chrome nut | F0197 |
| 3. Teflon tape. | N/A |
| 4. Plunger assembly | C6513P |
| a. O-rings | F0491 |
| b. lubricate (Petro-Gel) | F0298 |

Part No.

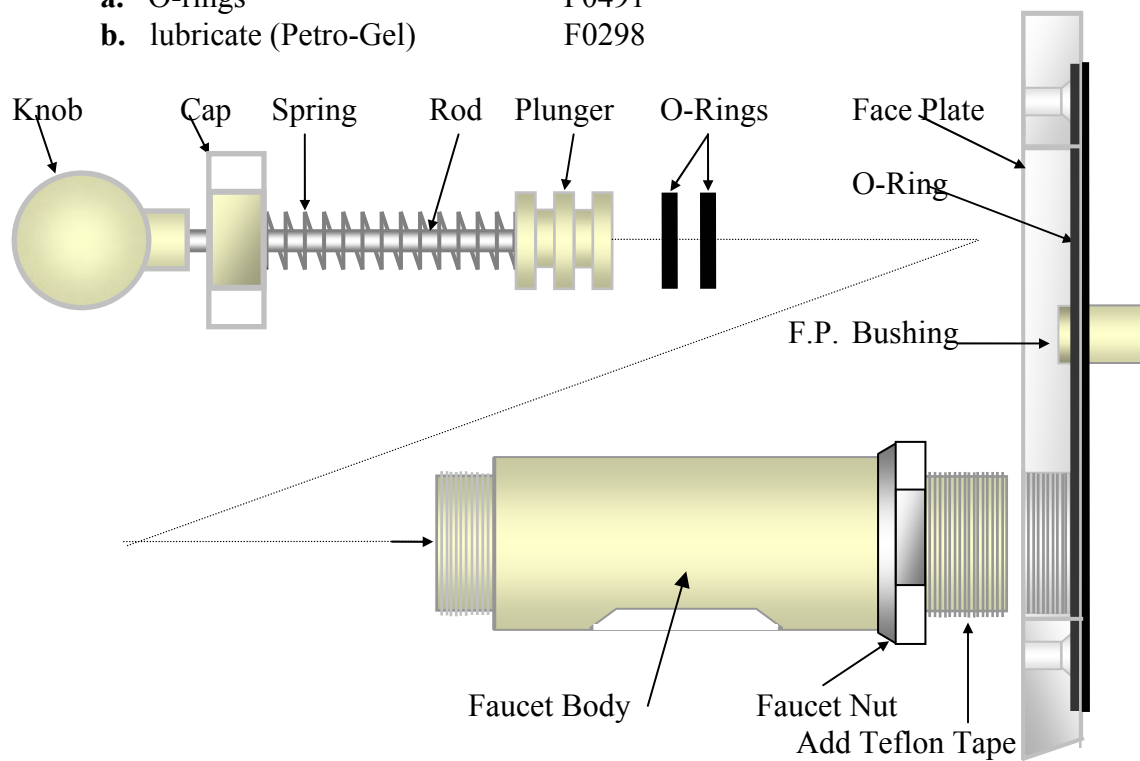

FLOAT SWITCH & THERMOSTAT ASSEMBLIES

FLOAT SWITCH ASSEMBLY

1. The float switch assembly consists of: Post switch, Float, Float clip, O-Ring and Nut.
2. There are two dots on one end of the float. When assembled the two dots must

- be on the top end of the float.
- Place O Ring so that it will be inside the hopper (sink bottom) when finished.

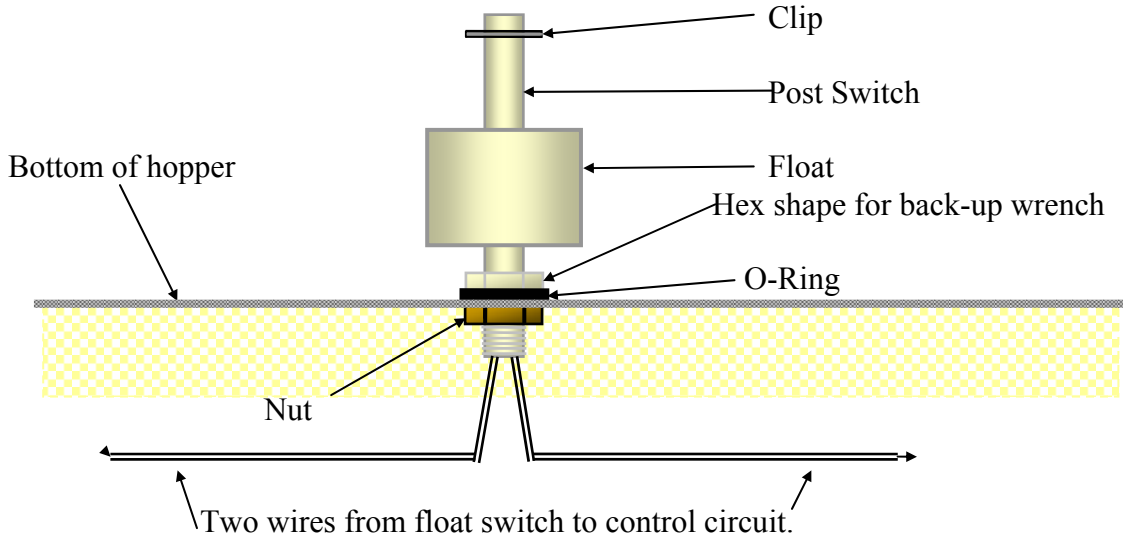

Top View of Float Switch

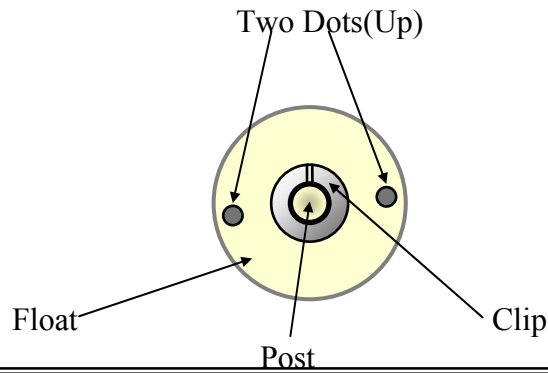

Thermostat System-Stand-By

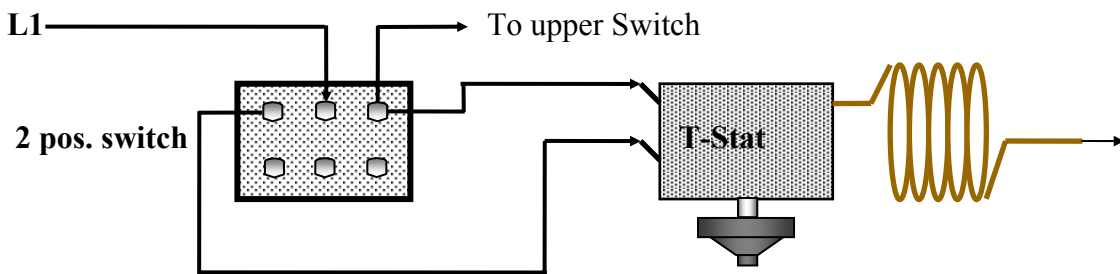

Drip Tube Brush Usage

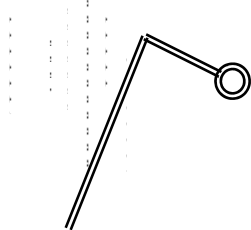

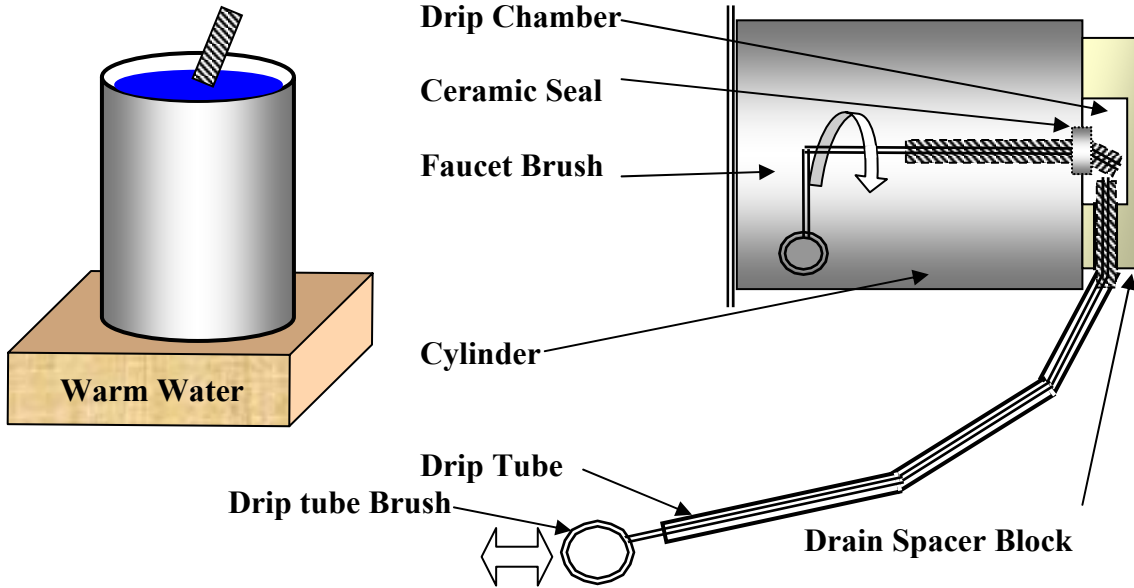

1. Dip the Faucet Brush in warm water.
2. Insert brush into the hole in the ceramic seal in the rear of the cylinder. Rotate the brush completely around to clean, as shown. Remove brush.
3. Dip the Drip Tube Brush in warm water and insert brush into drip tube.
4. Move brush back and forth to clean. Be sure the brush has been inserted completely into the Drip chamber.
5. Clean the brushes with hot soapy water when done.

Faucet Brush Usage

Use the Faucet Brush to clean the inside surfaces of the faucet as well as the inside of the ceramic seal in the cylinder.

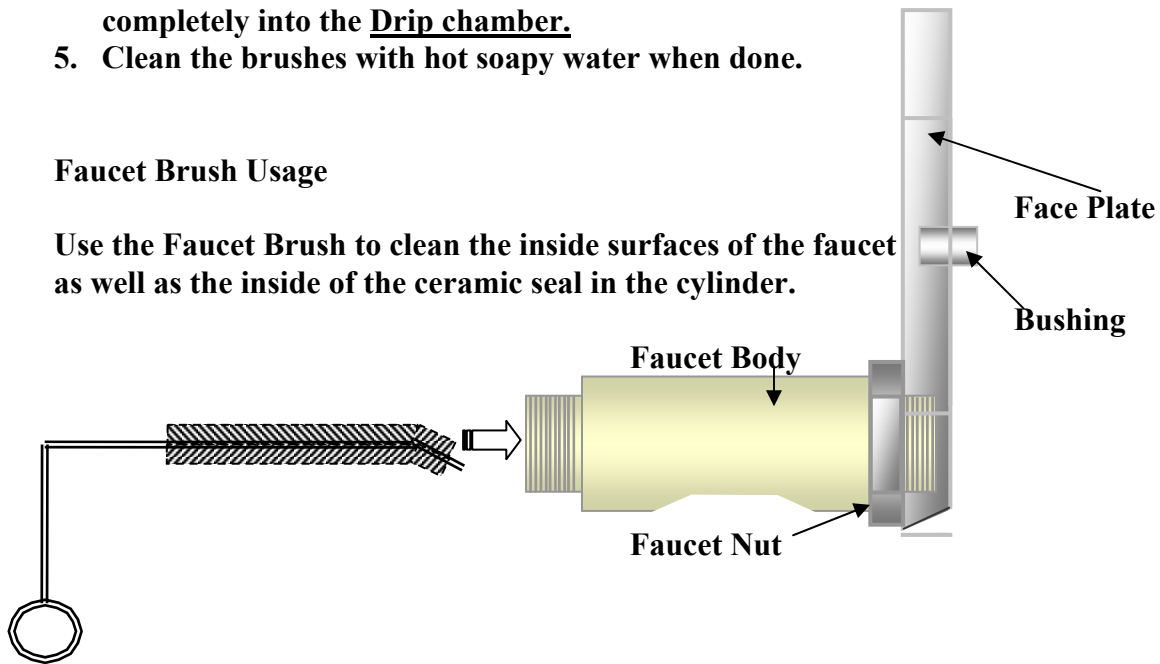

Beater Bar Spring Installation

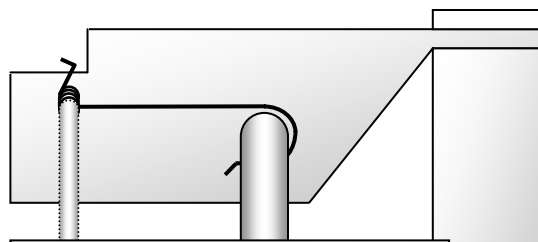

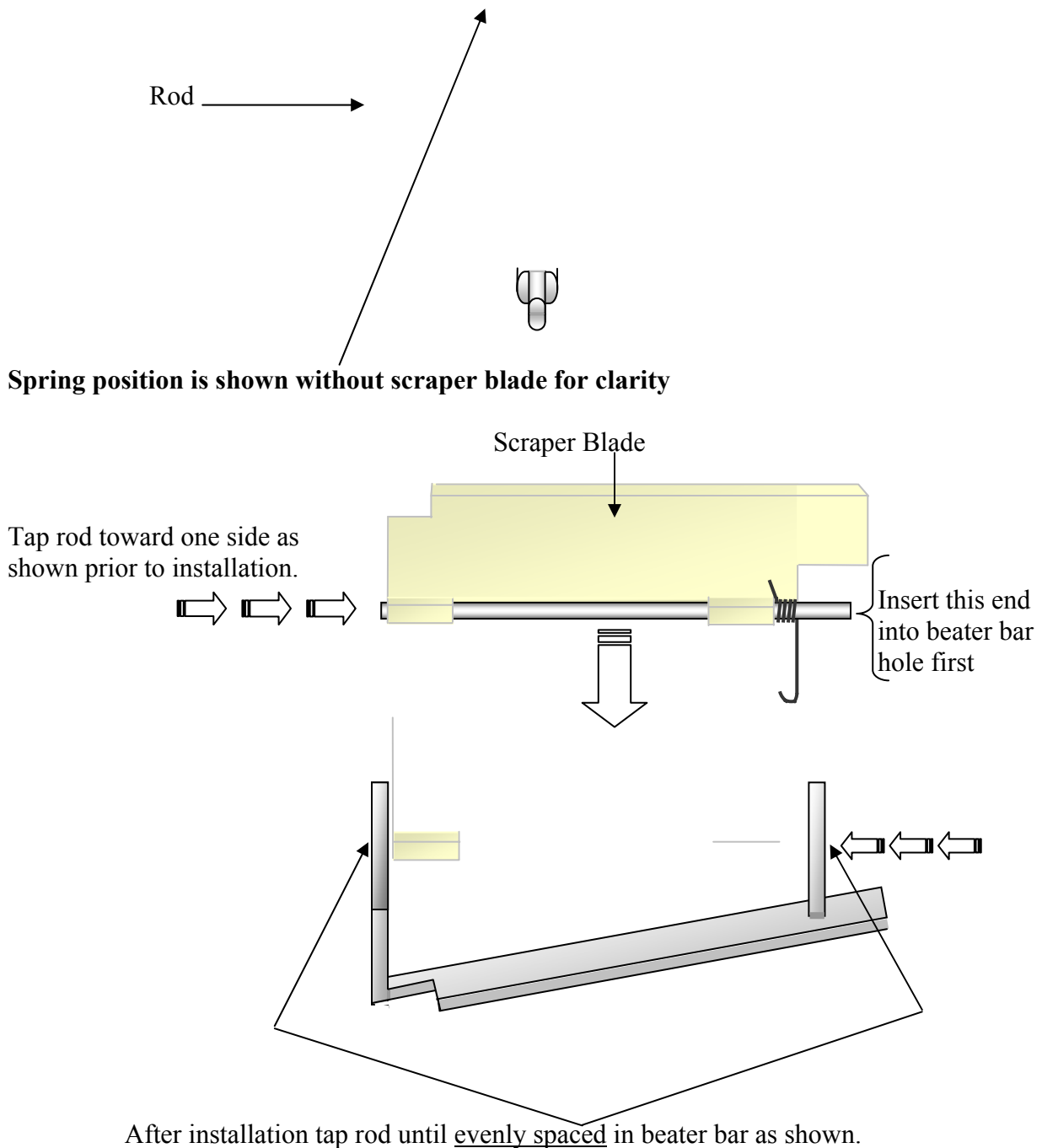

Beater Seal Assembly

1. Using Petro-Gel (or other sanitary food grade lubricant), lightly lubricate the longer end of the beater shaft. Slide beater seal onto the shaft with the spring end toward the beater bar. (Refer to diagram in this section of your manual or on top of the hopper cover for correct installation of spring seal).
2. The black carbon ring must be facing the end of the beater bar so it will be in direct contact with the white ceramic seal inside the cylinder when the beater bar is re-

installed. **This is a dry seal and must be kept free of lubricants.** Lube the beater bar shaft ONLY!

3. The beater seal may become damaged if the beater shaft is not lubricated before installation of the beater seal.

BEATER-BAR SEAL INSTALLATION

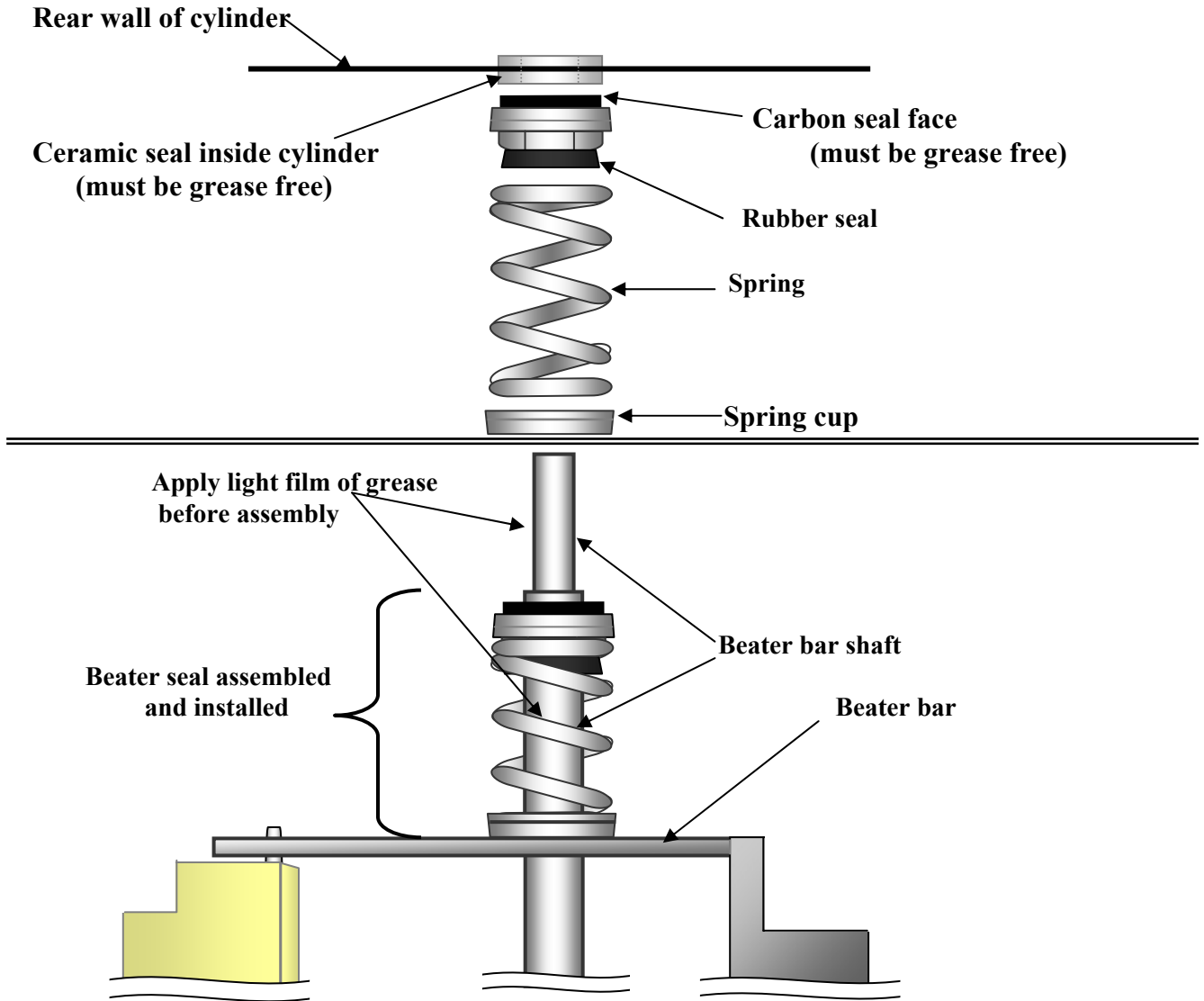

Ceramic Seal Removal and replacement

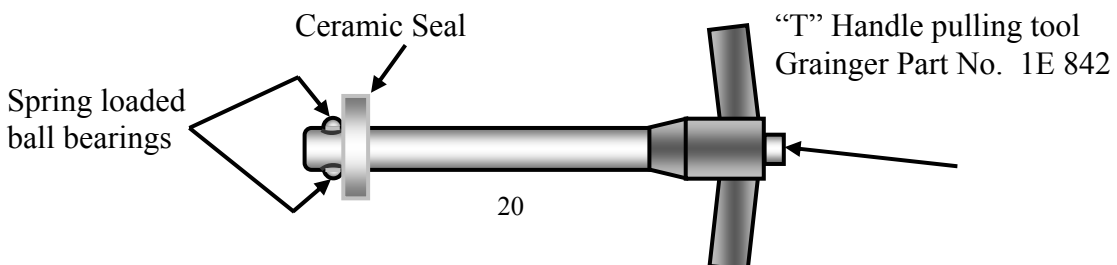

To remove old seal:

1. Press the “Push button” to release ball bearings.
2. Insert “T” handle through ceramic seal at rear of cylinder.
3. Release “Push button”.
4. Quickly pull “T” handle straight out and the ceramic seal will remain on the “T” handle as shown above.

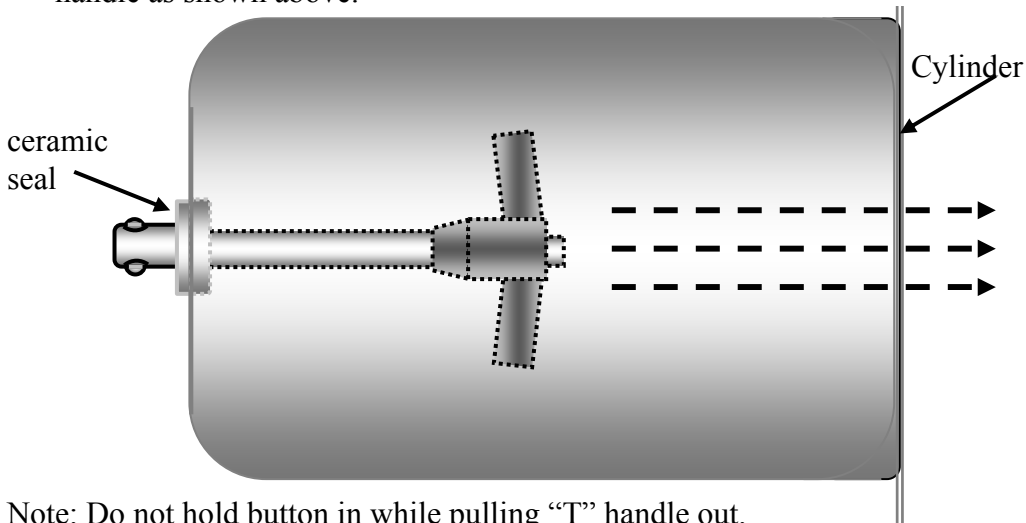

Note: Do not hold button in while pulling “T” handle out.

To install new seal:

1. Apply silicone around rear, grooved surface, of ceramic seal (Do not allow silicone to touch the smooth surface of the ceramic ring.)
2. Press seal into hole at rear of cylinder. Silicone coated surface goes in first.
3. Gently tap ceramic ring with wood or plastic rod until the seal has completely bottomed out. (The handle of a standard hammer works well if used carefully)
4. The smooth surface of the ceramic seal must be completely clean in order to provide proper sealing when the beater bar with spring seal is installed.
5. If possible allow at least four hours for silicone to cure before filling machine with product. If four hours are not available, place hair dryer 2 feet away for about 30 minutes. (Do not use the hottest setting).
6. Fill machine with product and check for leaks.
7. Machine is ready to run.

SPARE PARTS LIST
PETITE SORBETEER MODEL NO. 217A

DESCRIPTION

ITEM NUMBER

Compressor, 3/4 H.P.115/60/1	AKA9455ZXA-115/60
Run Capacitor	85PR370F20
Start Capacitor	85S250C30

Start Relay	820ARR3D10
Compressor, ¾ H.P. 230/60/1	AKA9455ZXD-230/60
Run Capacitor	85PR37036
Start Capacitor	85685
Start Relay	820ARR3C29
Rear Panel	F2006
Pressure Control Switch	F5567
Rear Cross Brace	F5578
Front Cross Brace	F5579
Air Condenser	F5565
Bearing Spacer Block	C2316B
Beater Bar	C6518
Beater Bar Spring Seal	F0355
C-Bracket	F1206
C-Bracket Stub	F1207
Contactors	F0478
Drip Tray	F6602
Drip Tray Screws	F0905
Drip Tube Brush	F6526
Drive Coupling	C0906
Drive Motor 115V	F0409
Drive Motor 230V	F0415
Drive Motor Start Capacitor 115V	F0430
Drive Motor Start Capacitor 230V	F0420
Face Plate	C6521
Face Plate Bushing	C6520
Face Plate Knob	F0264
Fan Blade	F5550
Fan Motor 115V	F5559
Fan Motor 230V	F5560
Fan Motor Bracket	F5500
Fan Shroud	F6466
Faucet Assembly	C6513
Faucet Body	C6513B
Faucet Brush	F0326
Faucet Nut	F0197
Faucet Plunger Assembly	C6513P
Faucet Spring	F0564
<u>DESCRIPTION</u>	<u>ITEM NUMBER</u>
Fill Light	F0207
Fill Light Switch	F0811
Filter-Dryer	F5595
Float Clip	F0812
Front Motor Bearing	F0427

Heat Sequencer	F0400
High Pressure Switch	F0661
Hopper Cover	F0498
Left Side Panel	F6436
Mercury Switch	F0209
Motor Adjustment Bracket	F1225
Motor Spring Bracket	F1239
O-Ring, Face Plate	F0357
O-Ring, Faucet	F0491
O-Ring, Fill Switch	F0161
Panel Louver	F0254
Petro-Gel	F0298
Rear Bearing Carrier	C1216
Rear Support Bearing	F0479
Right Side Panel	F6437
Sanitizer	F0492
Scraper Blade	C6510
Scraper Blade Spring	F6517
Sign Panel	F0171
Spring Adjustment Carrier	F1238
Stainless Steel Legs	F0800
Switch Nut	F7003
Switch, 2-Position, Bottom	F0417
Switch, 3-Position, Top	F0416
Tension Spring	F0432
Thermostat	F0401
Transformer-115V/230V	F4995

WIRE DIAGRAM