

Crathco® Beverage Freezers

SERVICE MANUAL for MODEL 3361B

TABLE OF CONTENTS

Description.....	2
Unpacking.....	3
Installation & Assembly.....	4 - 7
Cleaning & Sanitizing.....	6 - 9
Control & Product Issues.....	9 - 10
Service & Maintenance.....	10 - 12
Troubleshooting.....	13
Addendums.....	14 - 22

*Prior authorization must be obtained from
Grindmaster Corporation for all warranty claims.*



Model 3361B



Frozen Beverage Dispensers

Formerly Wilch

Grindmaster Corporation

4003 Collins Lane
Louisville, KY 40245 USA
(502) 425-4776 (800) 695-4500
FAX (502) 425-4664
www.grindmaster.com

General Description

This unit is specifically designed to freeze pre-mix product supplied from bulk storage containers. The 3361B contains an oil free air compressor used to supply compressed air to push product from bulk storage containers (or gas driven pumps) to the freezing cylinder. The freezer consists of a freezing cylinder with a rotating internal auger (dasher) that is belt driven by an electric motor. The auger scrapes frozen product off of the inside of the refrigerated cylinder. A torque sensing mechanism controls compressor operation to maintain desired product consistency. The freezer has an air-cooled refrigeration system which only cools the freezing cylinder. A clear, self-closing dispensing valve is attached to the front of the freezing cylinder. A pressure relief is incorporated into the dispensing valve that allows excess pressure to be vented. The unit has adjustable consistency and product out indicators.

3361B Description

Unit Part Numbers:	3361B	
Overall Dimensions:		
Height	26.5 in	67.3 cm
Width	13 in	33 cm
Depth	28.6 in	73 cm
Operating Weight: (approx.)	175 lbs.	80 Kg
Shipping Weight: (approx.)	195 lbs.	88.5 Kg
Compressor:	3/4 Hp	560 W
Refrigeration System:		
Refrigeration Type	404a	404a
Refrigeration Charge (See data plate)		
Expansion valve setting	35 PSI	240 Kpa
Ambient Operating Temp:		
Minimum Temperature	60°F	15°C
Maximum Temperature	100°F	37°C
Electrical Requirements:		
Operating Voltage	115 V	115 V
Current Draw	15 A	15 A

Theory of Operation

A self-contained air compressor, within the unit, supplies compressed oil-free air to the outlet connection of the machine. The air is delivered through the hose to the pre-mix product storage tank(s) or a gas driven product pump. The air is stored and develops pressure in the product storage tank(s). Pressure above product forces product out through the hose, to the inlet, to the machines. The product enters the rear of the machine and passes through internal hosing to the freezing cylinder. Product will flow from the storage tank(s) to the freezing cylinder until the pressure has equalized. As long as the tank(s) contain product, product will flow to the freezing cylinder during every dispense period. The air compressor will run and product flow will continue until the pressure has equalized between the freezing cylinder and the storage tank(s).

The machine contains a flow sensor that differentiates between liquid and air to allow the machine to signal a mix out condition.

Unpacking and Inspection

Shipment and Transit

The freezer has been operated and tested at the factory. Upon arrival, the complete freezer must be thoroughly checked for any damage which may have occurred in transit.

NOTE: A Tip (N) Tell warning device is placed on each shipping carton at the factory. If the arrow tip is blue, the carton has been tipped in transit. (See Figure A)

THE CARRIER IS RESPONSIBLE FOR ALL DAMAGE IN TRANSIT WHETHER VISIBLE OR CONCEALED. DO NOT ACCEPT THE SHIPMENT until the freezer has been checked for damage. Have the carrier note any visible damage on the freight bill. If concealed damage and/or shortage is found later, advise the carrier within 10 days and request inspection. The customer must place any claim for damage and/or shortage with the carrier. Grindmaster Corporation cannot make any claims against the carrier.

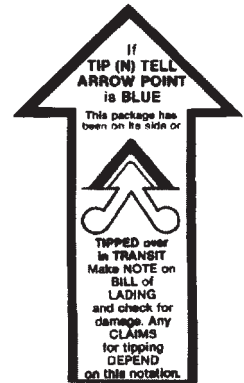

Figure A

Loose shipped parts

Part #	Name	Quantity
W0600108	Manual	1
W0600121	Header installation instruction sheet	1
W0631903	Sanitizer packets	6
W0600159	Warranty card	1
W0890218	Drip pan kit	1
W0340022	"O" ring #213	6
W0470076	Lubricant, Lubri-Film	1
W0480437	Plunger, Slush pressure W3361	1
W0480445	Handle, valve	1
W0631230	Spring, Compression for valve	1
W0470010	Pad, Neoprene Black Rubber	1
W0600073	Sheet, Caution Rubber Mat	1
W0470019	Cleaning Brush, Fas-pin 1/4"	1

Safety and Inspection

Safety Precautions

- 1) Read and understand the operating instructions in this manual thoroughly.
- 2) Note all warning labels on the freezer.
- 3) Do not wear loose fitting garments or jewelry that could cause a serious accident.
- 4) Stay alert at all times during operation.
- 5) Keep operating area clean.

Do not operate freezer if any excessive noise or vibration occurs. Contact an authorized service agent.

Installation

Installing Freezer

- 1) Unbox freezer
 - a) Remove both side panels and then use a 7/16" socket to remove the 2 bolts at the bottom of the freezer that hold it to the shipping pallet.
 - b) Cut the wire tie (note red tag) on freezer drive motor. (See Figure B)
 - c) Leave right side panel (when facing front of freezer) off.
- 2) Place beverage freezer onto the counter or cabinet on top of the rubber mat supplied.
- 3) Attach hose from the product tank(s) to the air supply connection (1/4" SAE flare). Attach hose from the product tank(s) to the product supply connection (1/4" SAE flare). (See Figure C)
- 4) Assemble the dispensing valve assembly. (See Figure D)
- 5) Turn "on/off/clean" switch on front of the unit to the OFF position.
- 6) Replace freezer right side panels.

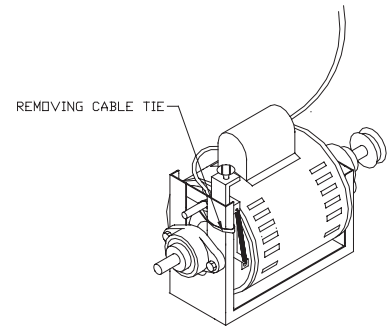

Figure B

Locating Freezer

- 1) Connect freezer to a properly grounded 115-120 VAC, 60 Hz single-phase electrical circuit with a 20-amp (NEMA 5-20R) minimum-rated disconnect switch (not provided) that is fused at 20 amps (slow-blow).

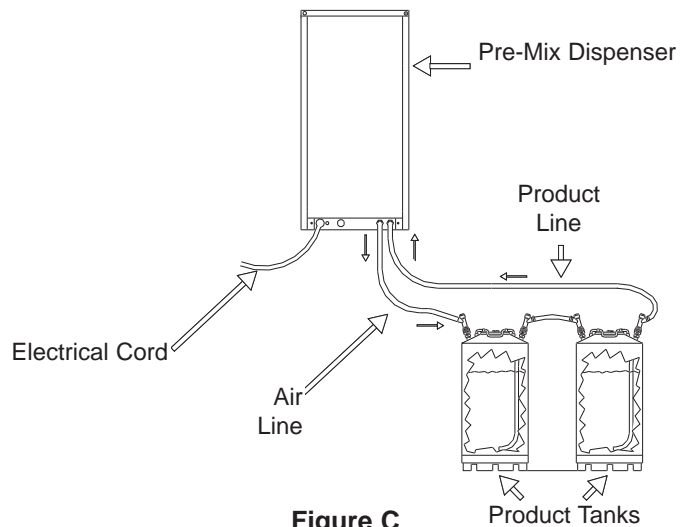

Figure C

⚠ CAUTION: Safe operation of this unit can only be achieved if the freezer is properly connected to an appropriate grounded, electrical receptacle that complies with current national safety standards. The manufacturer cannot be held responsible for damage and/or injury caused by failure to connect the unit to an appropriate source of power.

- 2) A minimum air clearance of 6" is required on both sides of the freezer during operation. (See Figure E)

⚠ CAUTION: Restricting air flow through the freezer will greatly reduce the output capacity as this is an "air-cooled" unit. Air is drawn in to cool the unit through the right side (facing front of freezer) and exhausted through.

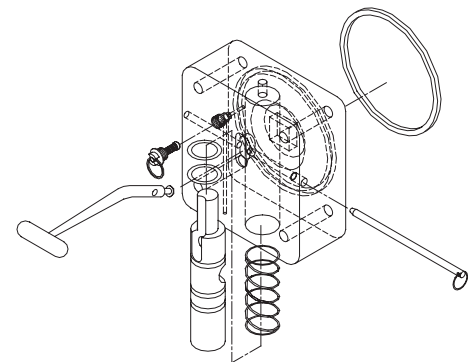

Figure D

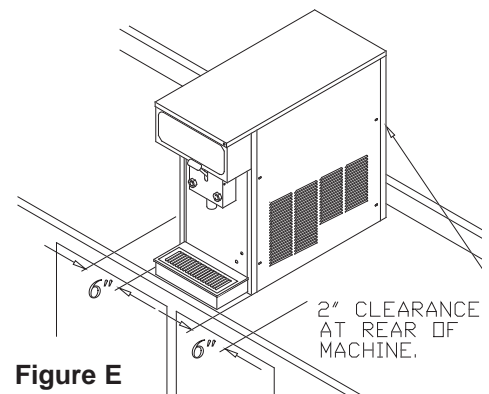

Figure E

Attaching Drip Tray

- 1) The drip tray is mounted on two screws that are located on the lower front of the freezer cabinet.
- 2) Place the key hole slot of the drip tray support bracket (W0471022) on to these screws and tighten the screws.
- 3) Angle the back of the drip tray surround bracket into the drip tray support bracket (W0471022) and lower bracket to lock it into place.
- 4) Place drip tray onto drip tray surround bracket.
- 5) Place the louvered drip tray insert into drip tray.

Installing the Product Storage Tank(s)

Check Air Compressor Set Point

- 1) Remove top plate to the freezer, by removing the four screws on each corner.
- 2) The recommended operating pressure for the compressor is between 10-25 psi. The remote located product storage tank(s) will operate safely up to 25 psi. The differential should be 5 to 7 psi.

⚠ CAUTION: The use of excessive pressure (above 25 PSI) will result in relief venting at the product tank(s).

Adjustment:

The scale plate directly indicates the cut-out and differential. The cut-in is calculated by subtracting the differential from the cut-out:

- 1) Adjust the range screw until the scale pointer indicates the desired cut-out setting (10-25 psi).
- 2) Adjust the differential screw until the scale pointer indicates the desired differential setting (5-7 psi). The cut-in setting equals the cut-out setting less the differential.

Mix Product for the Storage Tanks

For the dispenser to operate properly, the percent of dissolved solids (generally sugar) in the pre-mix product should be between 11 and 14 as measured by a refractometer (referred to as Brix). If the Brix of the pre-mix product is below 11 the product will freeze too hard and result in auger freeze-up. If the pre-mix product Brix is above 14 the product will not freeze quickly and will remain liquid.

NOTE: Brix is the percentage of sugar in the mix. The instrument called a refractometer reads Brix directly. A refractometer can be purchased from Grindmaster Corporation or most beverage supply companies. The amount of alcohol affects the performance of the machine. The machine can freeze up to 15% alcohol, however, the product will be liquid and runny. For best performance, the mix should contain 7-10% alcohol by volume.

Filling the Dispenser

It is recommended that a cleaning and sanitizing procedure be completed before dispensing product.

- 1) Turn the unit to "CLEAN" after connecting product storage tanks to the unit.
- 2) Allow the pressure to build in the compressed air system.
- 3) Product will begin to flow when the pressure begins to build.

Filling the Dispenser (cont'd)

NOTE: The dispenser contains a flow switch that is activated if the product does not flow in 15 seconds. To reset the flow switch cycle, turn the power switch to OFF and back to CLEAN.

- 4) Allow the product to fill the freezing cylinder until pressure equalizes between cylinder and product storage (approximately 30 seconds).
- 5) Switch machine to OFF position.
- 6) Pull relief valve O-ring. (See Figure F)
- 7) Repeat steps 1 through 6 until the freezing cylinder is full.

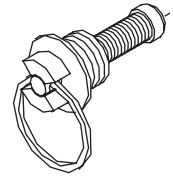

Figure F

NOTE: Unit may need to be vented 2-3 times on initial fill.

- 8) Turn machine ON.
- 9) Allow 15 to 20 minutes for product to freeze.

Cleaning and Sanitizing

⚠ CAUTION: Freezing cylinder may be under pressure. All product must be drained from the dispenser and pressure vented. Disconnect power before performing the following operations.

Removing Product from Barrel

- 1) Turn freezer switch to OFF.
- 2) Vent air pressure from storage tank using relief/vent valve on tank lid.
- 3) Disconnect hose from tank(s) and remove tank lid.
- 4) Pour remaining product from tanks.
- 5) Rinse tanks with clean water.
- 6) Fill tanks with clean water.
- 7) Replace lid and reconnect hoses.
- 8) Turn freezer switch to CLEAN.
- 9) Allow air pressure to build in tanks.
- 10) Place bucket under product dispensing valve.
- 11) Pull valve handle and begin dispensing product.
- 12) Remove product until all of the product in the cylinder is clear water.
- 13) Allow the freeze cylinder to fill with water. It will be necessary to switch the power to OFF and vent the air from the barrel by opening pressure relief on dispensing valve.
- 14) Switch unit from CLEAN to OFF.

Removing Product from Barrel (cont'd)

- 15) Relieve pressure from freeze cylinder by pulling relief valve ring.
- 16) Turn freezer switch back to CLEAN and allow cylinder to fill.
- 17) Allow unit to run in CLEAN for 5 to 7 minutes.
- 18) Turn freezer switch to OFF.
- 19) Drain all water. If flow stops before the cylinder is empty, pull vent (round ring) in valve block and break vacuum.

Cleaning

- 1) Disassemble the dispensing valve by first removing the dispensing valve pin. (See Figure G)
- 2) Push up on the dispensing valve plunger and pull out the dispensing handle. The plunger assembly complete with spring and "O" Rings can then be removed as a unit.
- 3) Remove knobs and carefully remove the freezer dispensing valve assembly.
- 4) Remove the O-Rings from the plunger assembly and back of the dispensing valve body.

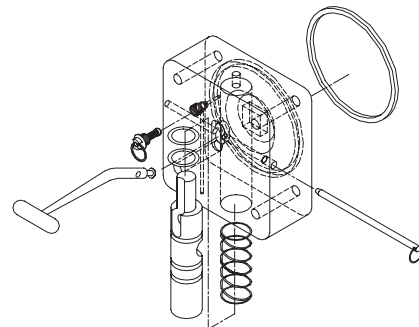

Figure G

NOTE: The best way to remove an O-Ring is to first wipe off all of the lubricant using a clean paper towel. Pinch the O-Ring upward with a dry towel between your index finger and thumb. When a loop is formed in the O-Ring, roll it out of the groove with your other thumb. Always remove the O-Ring farthest from the end of the plunger first. (See Figure H)

- 5) Carefully inspect the O-Rings for wear, nicks or cracking and replace if necessary.
- 6) Carefully pull out the auger assembly taking care to avoid damaging the rear seal assembly at the back of the freezing cylinder.
- 7) Remove the stationary portion of the shaft seal assembly (ceramic ring and rubber boot) from the back end of the freezer cylinder. This is accomplished by reaching into the cylinder and pulling the seal out with your index finger. (See Figure I)

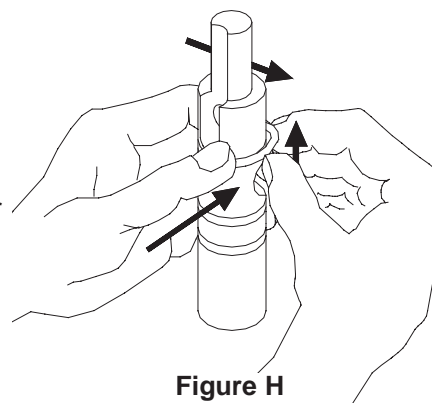

Figure H

- 8) Slide the rotary seal off of the auger shaft. Inspect both seal components carefully for nicks or cracks. Replace seal if defective.

NOTE: To prevent leakage, both surfaces of the seal must be smooth with no chips or cracks.

- 9) Wash all components in a detergent solution, sanitize and allow to air dry. (See Figure J) **DO NOT WASH COMPONENTS IN A DISHWASHER.**
- 10) Wet the inner rubber lip of the rotary portion of the seal and the back end of the auger shaft with water. Slide rotary portion of assembly onto the auger shaft, **RUBBER FIRST**, with the smooth sealing surface facing toward the back of the auger.

Cleaning and Sanitizing (cont'd)

- 11) Insert the stationary portion of the seal into the grooved rubber boot with the polished surface facing out (forward), away from the rubber boot. Lubricate the grooved rubber exterior portion of the boot with silicone lube and insert it straight back into the recess at the back of the freezing cylinder, RUBBER FIRST.

NOTE: If the circular portion of the seal is white, make sure that the groove is toward the rubber (back of freezer).

- 12) Reassemble the dasher assembly (see Figure K). Insert the larger front and smaller rear white plastic bearings into dasher, then slip in the stator rod. **Carefully and slowly guide the auger into the freezing cylinder taking care not to damage the seal assembly.** Turn auger shaft until it engages the square drive coupling.

- 13) Reassemble the dispensing valve assembly. (See Figure G) Be sure to lubricate o-rings and relief vent before assembling.

- 14) Thoroughly wash and sanitize all components. Inspect and **lubricate all surfaces of the large O-ring** and refit it into the rear of the valve assembly.

IMPORTANT: Failure to lubricate the large O-Ring can result in product leakage.

Install the valve assembly on the front studs and tighten knobs until they are finger tight. **Do not use tools to tighten knobs.**

- 15) Lubricate the inside bore of valve body with a thin film of food grade sanitary lubricant. Reinstall the O-rings on the plunger assembly and lubricate the entire plunger. Reassemble the valve and replace the retainer pin.

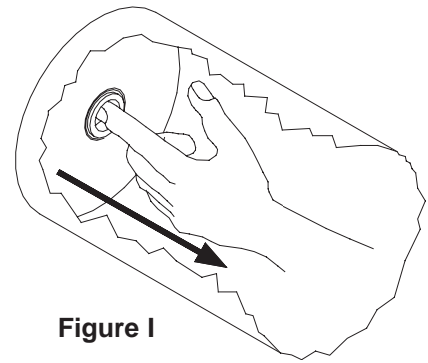

Figure I

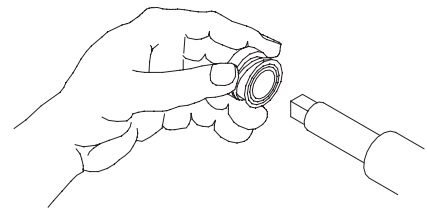

Figure J

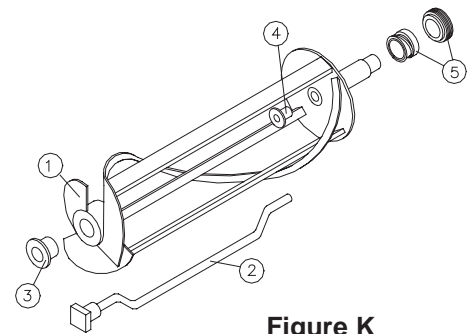

Figure K

Daily Cleaning of Unit

The exterior of the unit should be cleaned as needed, at the end of the operating day. Remember to empty and clean the drip tray and drip tray bracket.

⚠ CAUTION: Course rags, abrasive cleaners, and excessive force can damage and/or destroy the surfaces of this unit.

Sanitizing

- 1) **Disassemble the freezer and disconnect storage tanks following the steps in the previous section.**
- 2) **After disassembly, thoroughly scour each part of the freezer in a warm, mild detergent solution including the inside of the freezing cylinder.**
- 3) **Rinse each part with clean water.**
- 4) **Prepare a minimum of 2 gallons (7.6 liters) of sanitizing solution (Divorsol CX or equivalent).**
NOTE: Add 1.75 ounces (51 ml) of Divorsol CX to 2 gallons (7.6 liters) of 120°F (50°C) water to achieve a concentration of 500 parts per million. Dip or wipe each part in sanitizing solution and allow them to air dry on clean paper toweling.
- 5) **Pour 1-1/2 gallons of sanitizing solution into the storage container(s) and reseal. Use remaining solution for sanitizing small parts.**

Sanitizing (cont'd)

- 6) Reassemble unit and reconnect storage tanks following assembly instructions.
- 7) Turn freezer switch to "CLEAN".
- 8) Allow the freeze cylinder to fill half way with sanitizer.
- 9) Turn the freezer switch from "CLEAN" to "OFF".
- 10) Open the pressure relief valve located on the freezer dispensing valve to relieve all of the pressure in the freeze cylinder.
- 11) Turn the freezer switch to "CLEAN" and allow the freezing cylinder to fill to the relief valve.
- 12) Allow unit to run in "CLEAN" for 5 minutes.
- 13) Purge sanitizer from product lines and barrel.
 - a) Turn freezer OFF.
 - b) Vent air pressure from storage tank using relief/vent ring.
 - c) Disconnect hose from tank(s) and remove lid.
 - d) Pour any remaining sanitizer from tanks.
 - e) Rinse with clean water or as recommended by your state/local health department.
 - f) Fill tanks with product.
 - g) Replace lid and reconnect hoses.
 - h) Place bucket under product valve.
 - i) Pull product handle and begin removing sanitizer.
 - j) Turn freezer switch to CLEAN.
 - k) Allow air pressure to build in tanks.
 - l) Dispense product until all sanitizer is purged from the product lines and freeze cylinder.
- 14) Turn freezer switch to ON and allow 15 to 20 minutes for product to freeze.

Controls and Product Issues

Faceplate Relief Valves

A spring-loaded pressure relief valve maintains a safe pressure in the freezing cylinder. When filling the cylinder the relief valve acts as a vent to allow the CO₂ and air trapped in the freezing cylinder to escape. Venting the freezing cylinder is essential to obtain proper overrun. The vent is also used to break a vacuum when draining a unit.

Dispensing Valve

⚠ CAUTION: The product on the freezing cylinder is under pressure, open the dispensing valve slowly when dispensing product.

Consistency Adjustment

NOTE: The following product consistency (thickness) control adjustment procedure requires removal of the right side panel. It is suggested that a qualified service technician make this adjustment because side panel removal exposes hazardous moving parts.

WARNING: Do not attempt freezer adjustments until electrical power has been disconnected.

Consistency Adjustment (cont'd)

It may become necessary to readjust the consistency setting (thickness) to compensate for variations between different types of mixes and overrun settings.

- 1) Disconnect electrical power.
- 2) Remove right side panel (facing freezer).
- 3) Use the adjustment screw located on the top, front of the drive motor mounting bracket to change product thickness. (See Figure L)
 - Clockwise for thicker product consistency.
 - Counterclockwise for thinner product consistency.

NOTE: It may require up to three 180° turns of this adjusting screw to see a noticeable change in the product thickness.

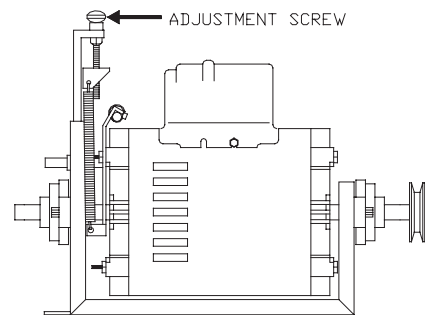

Figure L

- 4) Turn freezer to "ON" and allow it to freeze to desired consistency.
- 5) Wait 15 to 20 minutes, check product consistency (thickness) and repeat as needed.
- 6) Reinstall side panel and reconnect power.

Mix Out Light

Red indicator light, located on the front of the freezer, illuminates if the unit runs out of product. **When light is on, the unit will not fill or freeze product.**

Service and Maintenance

Servicing Dispensing Valves, O-Rings, and Freeze Cylinder Drive Shaft/Seal Assemblies

NOTE: Dispensing valve "O" Rings should be replaced **every 120 days** to correspond with quarterly preventative maintenance visits.

The best technique for removing an "O" Ring is to first wipe off all of the lubricant using a clean paper towel. Pinch the "O" Ring upward with a dry towel between your finger and thumb. When a loop is formed in the "O" Ring, roll it out of the groove with your thumb. Always remove the "O" Ring farthest from the end of the plunger first. (See Figure H)

Lubricating Plunger O-Rings

- 1) Place freezer in "**CLEAN**" position.
- 2) Drain freeze cylinder while purging with water.
- 3) Turn freezer control switch to the "**OFF**" position.
- 4) Vent pressure and drain completely.
- 5) Remove dispensing valve plunger.
 - a) Remove valve handle retaining pin.
 - b) Push plunger up and remove handle.
 - c) Pull plunger down.
- 6) Remove "O" Rings and clean "O" Ring grooves.
- 7) Replace "O" Rings.
- 8) Lubricate the "O" Rings on the plunger and the area inside of the clear plastic valve body where the plunger "O" Rings make contact with the valve body using silicone lubricant.

Lubricating Plunger O-Rings (cont'd)

- 9) Replace Plunger assembly.
 - a) Place spring on top of plunger.
 - b) Place plunger in valve body making sure that the handle opening faces forward.
 - c) Push up on plunger and replace handle.
 - d) Insert handle retaining pin.
 - e) Sanitize unit following instructions in manual.
- 10) Refill unit following instructions in manual.

NOTE: Plunger o-rings, face plate quad ring, shaft seal set, motor belt, etc. should be replaced at minimum annually.

Changing Back Lit Sign Merchandiser Bulb

- 1) Remove the two screws, located on the top of either side of the sign.
- 2) Lower the metal enclosure that frames the merchandiser insert.
- 3) Pull merchandiser enclosure down and out.
- 4) Replace bulb inside.
- 5) Reassemble.

Cleaning Condenser Coil

- 1) Turn machine "OFF".
- 2) Remove both freezer side panels.
- 3) Place a wet towel on the inlet side of the condenser (right side facing front of freezer).
- 4) Use compressed air to blow out condenser coils from the exhaust side of the condenser coil (fan motor side).

NOTE: Follow all health and safety standards.

- 5) Replace side panels.

Drive Belt Adjustment

⚠ CAUTION: Unplug machine before performing any adjustments. Check the belt tension quarterly. Proper belt tension is 1/2" deflection measured mid way between the drive and the driven pulleys (See Figure N). If the deflection is more that 1/2" adjust the motor height to achieve proper tension using the following procedure:

- 1) Unplug the unit and remove the side and rear panels.
- 2) Locate the motor flange bearings (W0380009) located at each end of the drive motor. Two bearings support the motor, one on the shaft at each end of the motor. The bearings are secured to the motor cradle using two Allen bolts on each bearing.
- 3) Loosen all four bearing Allen bolts.

NOTE: Do not loosen the setscrews that hold the bearing collars to the motor shaft.

- 4) Lower or raise the motor as needed to achieve proper belt tension. The motor must always be kept level from front to back.

NOTE: Excessive belt wear and belt noise can occur if the motor is not kept level.

- 5) Tighten all four Allen bolts down.
- 6) Align the driven motor pulley with the top driven pulley if needed. Use a straight edge along the top pulley. If the pulleys are not in alignment, remove the setscrew from the pulley and move either in or out as needed.

NOTE: Use a non-permanent Loc-Tite on the driven pulley setscrew and tighten down on the flat of the motor shaft.

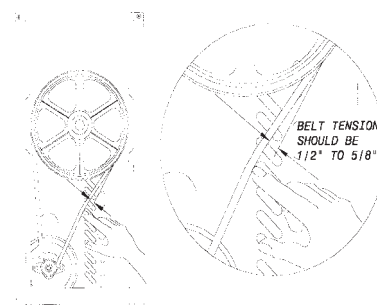

Figure N

Parts Replacement Schedule

Part Description	Monthly	Every 3 Months	Every 6 Months	Annually	Quantities to be Replaced
Drive shaft seal W0340201		Inspect & replace if necessary		Replace	1
Drive shaft W0451067				Inspect & replace if necessary	1
Drive belts W0450209				Inspect & replace if necessary	1
Scraper blades on dasher W1431084		Replace			2
Square cut o-ring on valve body/face plate W0340055			Inspect & replace if necessary		1
Front stator flange bearing W0430032			Inspect & replace if necessary		1
Rear stator flange bearing W0430024			Inspect & replace if necessary		1
Dispense valve o-rings W0340022		Replace			3
Dispense valve relief valve W0650429			Inspect & replace if necessary		1
Inlet tube o-rings W0340011				Inspect & replace if necessary	2
Condenser W0200256		Inspect & replace if necessary			1

Troubleshooting Guide























Problem	Probable Cause	Remedy
Machine won't run (no lights, no motor)	<ul style="list-style-type: none"> Machine not plugged into wall receptacle Building circuit breaker tripped or fuse blown Switches in wrong position 	<ul style="list-style-type: none"> Plug machine directly into outlet. Do not use extension cord. Place circuit breaker in the ON position or replace fuse Turn Freezer Switch to ON.
Machine will not freeze	<ul style="list-style-type: none"> Dasher assembly not installed Drive belt broken or off pulley Inadequate airflow Freezer in CLEAN position Mix low light on indicating an <i>out of condition</i> Condenser clogged Compressor not operating Low refrigerant charge 	<ul style="list-style-type: none"> Install dasher assembly Repair or replace Allow 6" (15cm) on both sides Switch to ON Correct <i>out of condition</i> Clean condenser Check for cause and correct Check for leaks, repair and recharge
Product too soft	<ul style="list-style-type: none"> Consistency adjuster set too low Consistency setting at maximum Too much alcohol in product Product BRIX level too high MIX LOW light on 	<ul style="list-style-type: none"> Readjust consistency Change to yellow consistency spring Correct mix ratio Correct mix ratio Refill empty product
Product too thick	<ul style="list-style-type: none"> Consistency adjuster set too high Too little alcohol Product BRIX level too low 	<ul style="list-style-type: none"> Readjust consistency setting Correct mix ratio Correct mix ratio
Product will not dispense	<ul style="list-style-type: none"> Power switch OFF MIX LOW light on Consistency adjuster set too high Drive belt broken or off pulley No compressed air Product tank connections reversed 	<ul style="list-style-type: none"> Turn power switch ON Refill empty product Readjust consistency setting Repair or replace Check air compressor Check product tank connections
Leakage from drip tube	<ul style="list-style-type: none"> Worn out or defective drive shaft seal 	<ul style="list-style-type: none"> Replace seal and then lubricate at each cleaning
Excessive Dispensing Valve leaks	<ul style="list-style-type: none"> Worn or defective o-ring(s) Excessive pressure from product delivery system 	<ul style="list-style-type: none"> Replace and lubricate each cleaning Re-adjust air pressure
Clicking sound from inside machine	<ul style="list-style-type: none"> Low voltage Extension cord is used 	<ul style="list-style-type: none"> Use dedicated circuit with proper rating Connect directly to power source or use power cord of proper size
Thumping sound from inside machine	<ul style="list-style-type: none"> Worn belt Product BRIX level too low Low alcohol content in product 	<ul style="list-style-type: none"> Replace belt Correct mix ratio Check mix
Product does not feed	<ul style="list-style-type: none"> Low air pressure Product pumps defective Carbonator pump defective Transformer defective Solenoids defective 	<ul style="list-style-type: none"> Check air compressor operation or air lines for leaks Replace pumps Replace pumps Replace transformer Replace solenoids
Premature seal wear	<ul style="list-style-type: none"> Incorrect installation of dasher Improper drive shaft clearance 	<ul style="list-style-type: none"> Advise careful installation Adjust to proper clearance

If you still need help, call an authorized dealer in your area or Grindmaster Corporation's Technical Service Department. You can reach Technical Service at (800) 425-4776 Monday-Friday, 8:00 AM-6:00 PM Eastern Standard Time. Please have the model and serial number ready so that accurate information can be given. Prior authorization must be obtained from Grindmaster Corporation's Technical Service Department for all warranty claims.

Machine Assembly

Do not cover ventilation grill on sides of machine.
 Read equipment instructions before handling parts.
 Assemble parts in numerical order as shown.

CHECK LIST

- 1 Stationary Seal Rubber Part  
- 2 Stationary Seal Ceramic Part  
- 3 Spring Seal  
- 4 Dasher  
- 5 Plastic Rear Bearing  
- 6 Plastic Front Bearing  
- 7 Stator Rod  
- 8 Large O-Ring  
- 9 Valve Body  
- 10 Valve Knobs  
- 11 Valve Plunger  

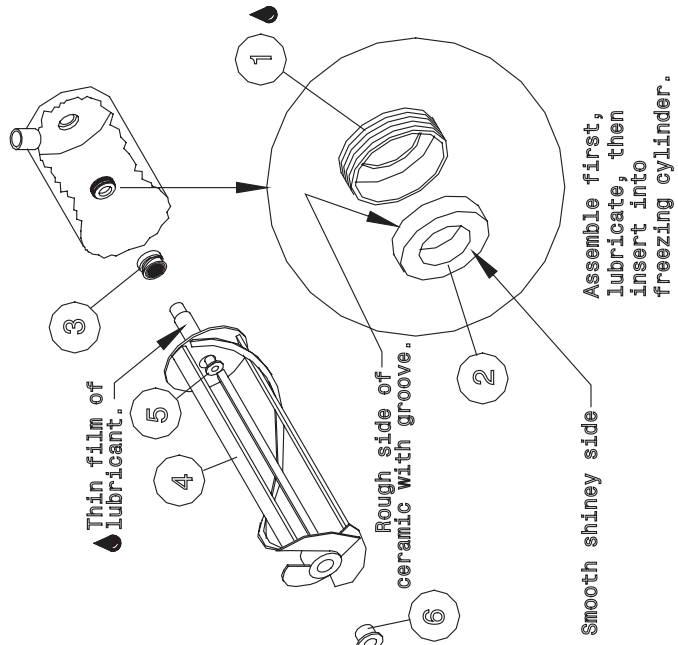

Add o-rings to plunger first,
 then lubricate plunger and o-rings.

Complete Unit Exploded View

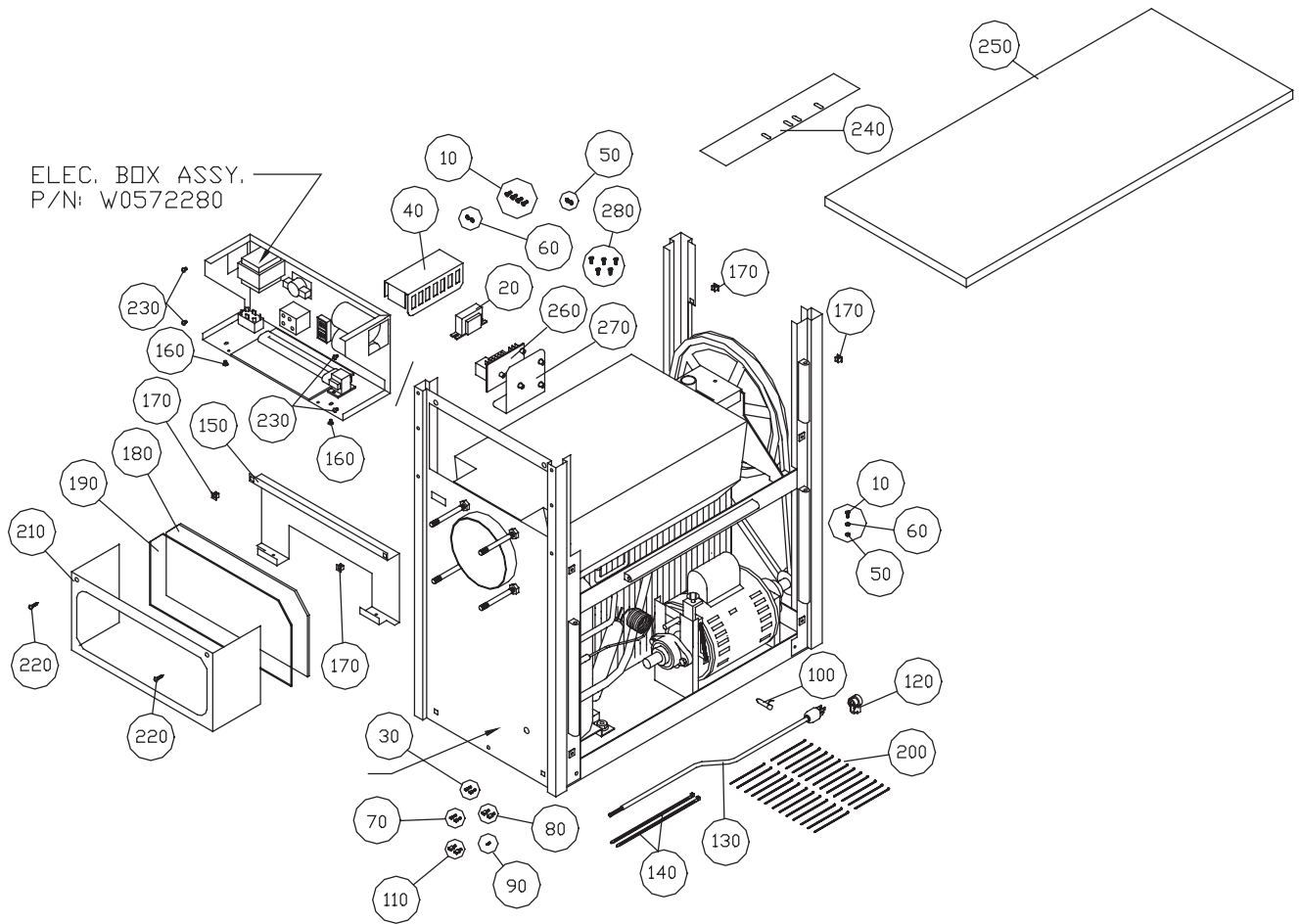

ITEM	PART NUMBER	DESCRIPTION
10	86807	8-32 x 3/8 Slt. BD HD Screw
20	W0570045	Ballast
30	W0570206	Terminal, Red Female
40	W0211086	Ballast Cover
50	W0611044	8-32 Nut, Z/P
60	83151	#8 External Star Washer
70	W0570207	Faston, Blue, Female Fully Insul.
80	W0570208	Faston, Blue, Male Fully Insul.
90	W0570308	Ring Eye, Blue #10
100	W0570901	Mercury Switch
110	W0570205	Faston, Red, Male Fully Insul.
120	W0630604	Strain Relief Bushing
130	W0572069	Power Cord
140	W0630802	Cable Tie
150	W057290	Light Reflector

ITEM	PART NUMBER	DESCRIPTION
160	W0610624	10-24 x 1/4 Screw
170	71373	Nylon Screw Anchor
180	W0631610	Front Display Lens
190	W0631614	Acrylic Lens
200	86600	Wire Tie
210	W0572452	Electrical Box Cover
220	W0610127	#8 x 3/4 S.S. TR. HD. Phil. Screw
230	W0610265	10-24 x 1/4 Rnd. Hd. Phil. Screw
240	W0201194	Baffle, Air, Top
250	W0201130	Top Plate, Pressure S.S.
260	90359	Level Control
270	W0571050	Control Board Support
280	61304	6-32 x 1/2 Phil. Pan HD Screw
290	W0571602	Pressure Comp. Wire Bundle
290	W0571601SH2	Reference, Wiring Diagram

Freezer Base Exploded View

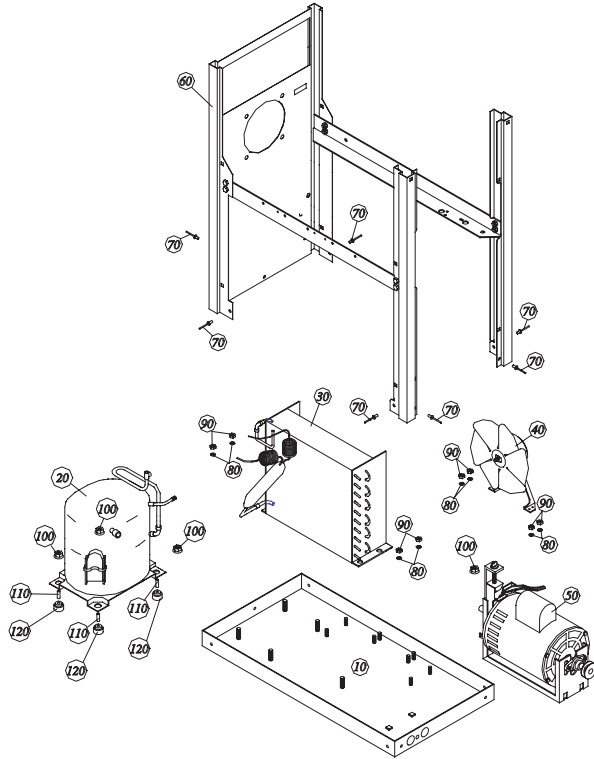

ITEM	PART NUMBER	DESCRIPTION
10	W0201752	Base Pan Assembly
20	W0201001	Compressor Assembly
30	W0201002	Condenser Assembly
40	W0321029	Fan Sub-Assembly
50	W0321026	Drive Motor Assembly
60	W0210083	Frame Assembly
70	W0611410	Rivet, Magna-Lok
80	W0611247	1/4 Int. Tooth Lk. Wshr.
90	W0611074	1/4-20 Hex Nuts
100	W0611082	5/16-18 Flange Nut
110	W0200412	Compressor Spacer
120	W0200413	Compressor Grommet

Freezer Exploded View

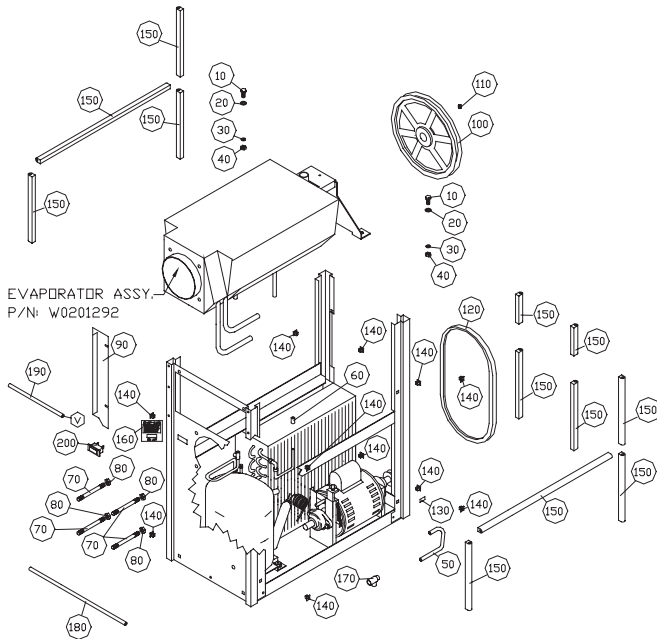

ITEM	PART NUMBER	DESCRIPTION
10	W0610682	5/16-18 x 3/4 Hex Hd. Cap Screw
20	W0611254	5/16 Flat Washer
30	W0611255	5/16 Split Lock Washer
40	W0611086	5/16-18 Hex Nut Z/P
50	W0201191	Suction Line Pressure
60	W0620103	3/8 Copper Couple
70	W0110013	Valve Studs
80	W0611085	5/16-18 S.S. Hex Nuts
90	W0201192	Air Baffle Side Piece
100	W0450053	10" Pulley
110	W0610646	Screw, Set, 5/16-18 x 3/8
120	W0450209	V-belt
130	W0600029	Motor Serial Plate
140	71373	Nylon Screw Anchor
150	W0670008	Trim-Lok Rubber Strip
160	W0600215	ON-OFF-CLEAN Label
170	W0620106	Tee, 1/2 x 3/8 x 3/8 Copper
180	W0201008	Low Side Process Tube
190	W0201006	High Side Process Tube
200	60033	Indicator Light

Product Feed Components

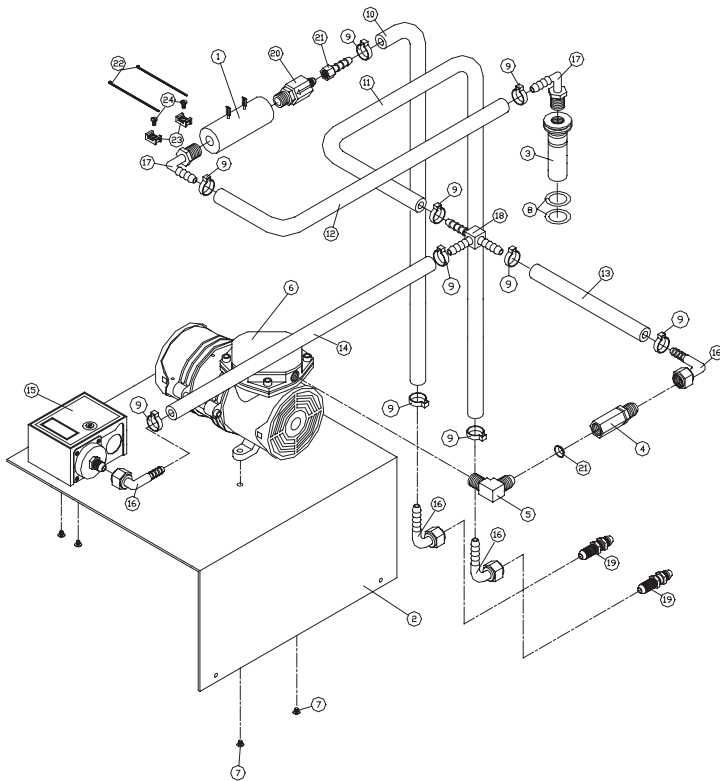
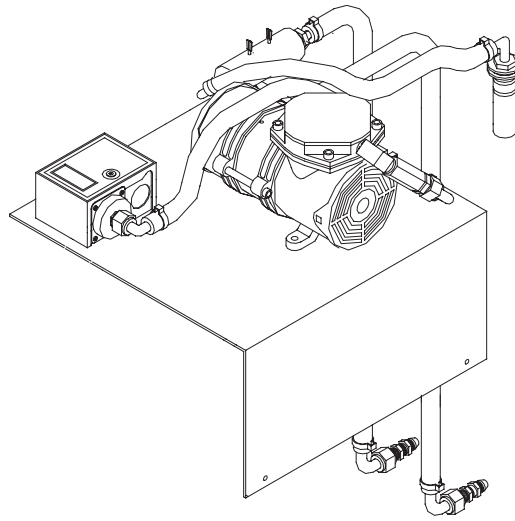

ITEM	PART NUMBER	DESCRIPTION
1	W0200901	Flow Switch
2	W0200160	Pressure Component Support
3	W0471115	Pressure Fill Inlet
4	90758	Check Valve
5	60057	Elbow, Brass
6	W0950035	Pressure Pump
7	W0610345	Screw, 10-32 x 1/4 Truss HD
8	W0340011	O-rings
9	60593	Oetiker Clamp 5/8
10	60591	Braided Soda Hose
11	60591	Braided Soda Hose
12	60591	Braided Soda Hose
13	60591	Braided Soda Hose
14	60591	Braided Soda Hose
15	W0650414	Low Press. Controller (RANCO)
16	W0620006	S.S. Swivel Hose Elbow 1/4 x 1/4
17	W0620007	S.S. Male Hose Elbow 1/4 x 1/4
18	90869	Hose Tee 1/4 x 1/4 x 1/4
19	70451	Male Flare Bulkhead 1/4
20	60054	Valve, Check 1/4 MPT x 1/4 MF
21	W0620003	Female Flare Hose Nipple
22	86600	Wire Tie
23	W0630455	Holder, Wire Tie
24	W0610136	8-32 x 1/4 Pan HD Sltd.

Electrical Box Exploded View

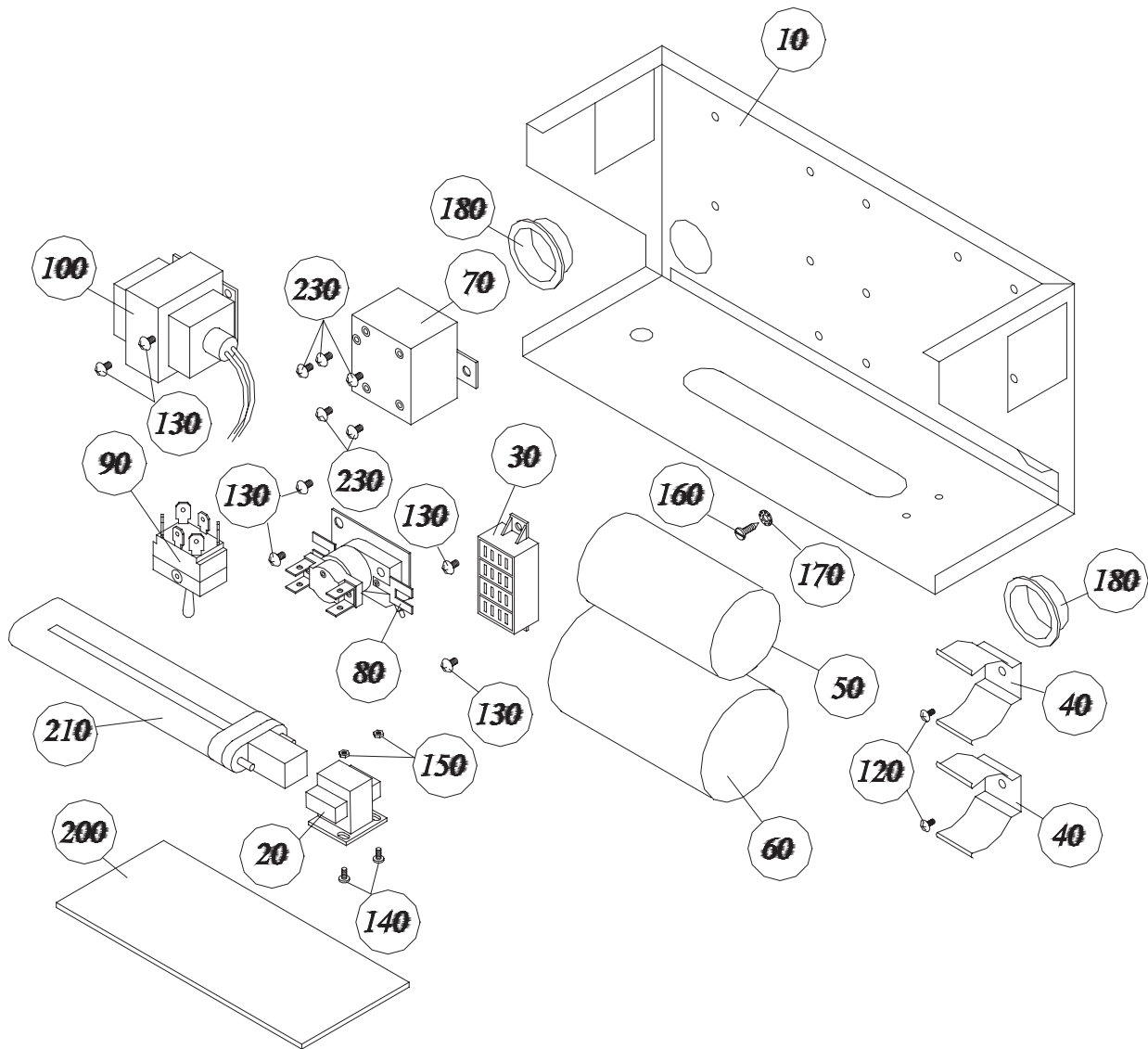

ITEM	PART #	DESCRIPTION
10	W0572287	Electrical Box
20	W0570044	Light Socket
30	W0570235	Terminal Block
40	W0630811	Small Capacitor Clip
50	W0570603	Start Capacitor
60	W0570617	Run Capacitor
70	W0570638	Compressor Relay
80	W0570651	Sequencer
90	W0570924	Toggle Switch
100	W0572032	Transf. Sub-Assy.
110	W0572192	Mix Low Sub Assy.
120	83248	6-32 X 1/4 Truss HD.

ITEM	PART #	DESCRIPTION
130	W0610131	8-32 x 1/4 Screw
140	W0610015	6-32 x 1/4 Slotted Screw
150	86827	6-32 Hex Nut Z/P
160	61272	#8 Ground Screw
170	83151	#8 External Star Washer
180	W0630006	Heyco Bushing, 1-1/4
190	86600	Wire Tie
200	W0631606	Elec. Box Lens
210	W0570043	Fluorescent Bulb
220	W0571000	Wire Harness 3311
230	W0610132	8-32 x 1/4 Screw
240	W0572202SH2	Elec. Wiring Ref. Drawing

3361B Ladder Diagram

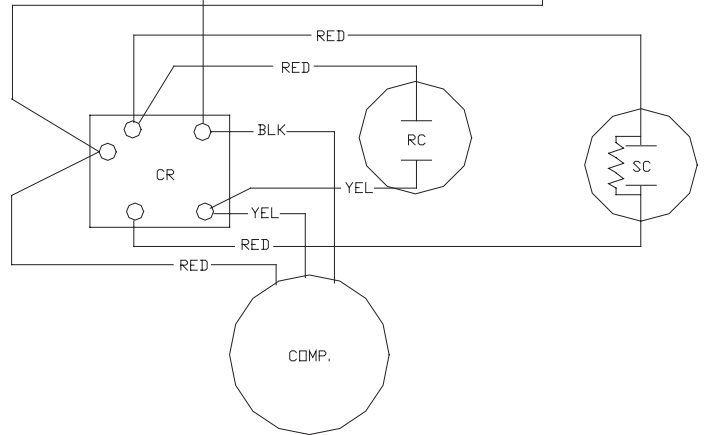
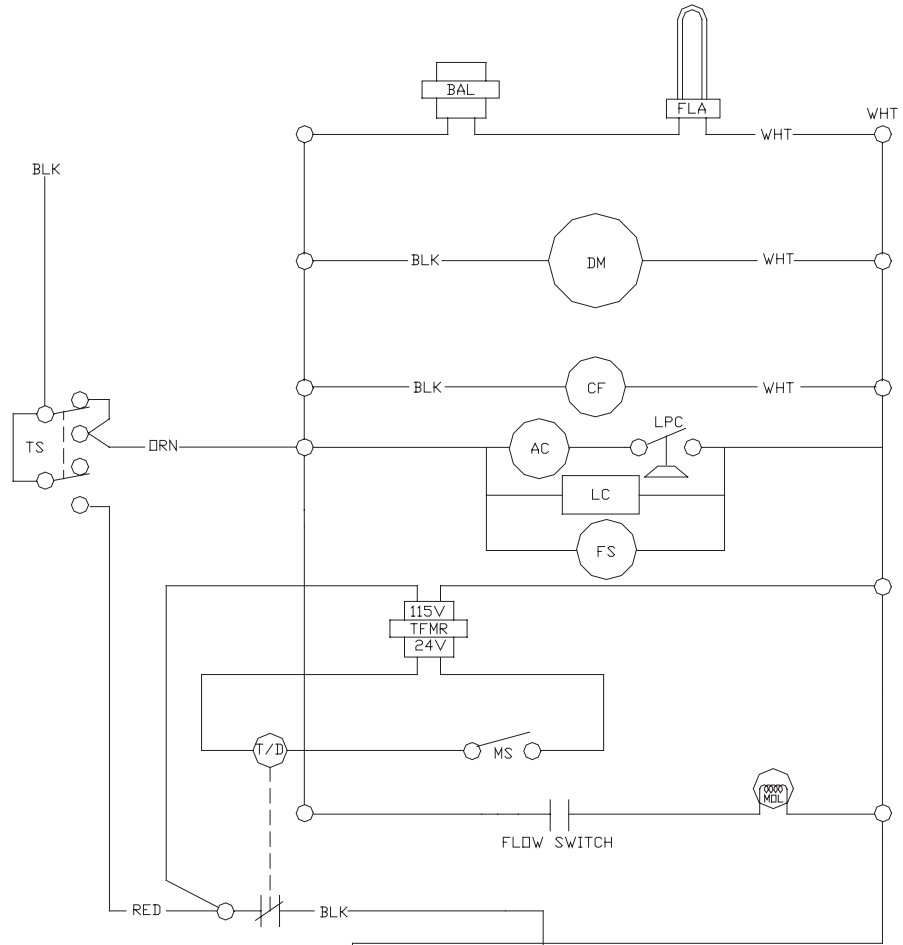

ABBREV.	PART
BAL	Ballast
FLA	Florescent Lamp
DM	Drive Motor
CF	Cooling Fan
TS	Toggle Switch
TFMR	Transformer
FS	Flow Sensor
MS	Mercury Switch
T/D	Time Delay Relay
LPC	Low Pressure Controller
AC	Air Compressor
LC	Level Controller
CR	Compressor Relay
RC	Run Capacitor
SC	Start Capacitor
COMP	Compressor
MOL	Mix Out Light

3361B Freezer Electrical Schematic

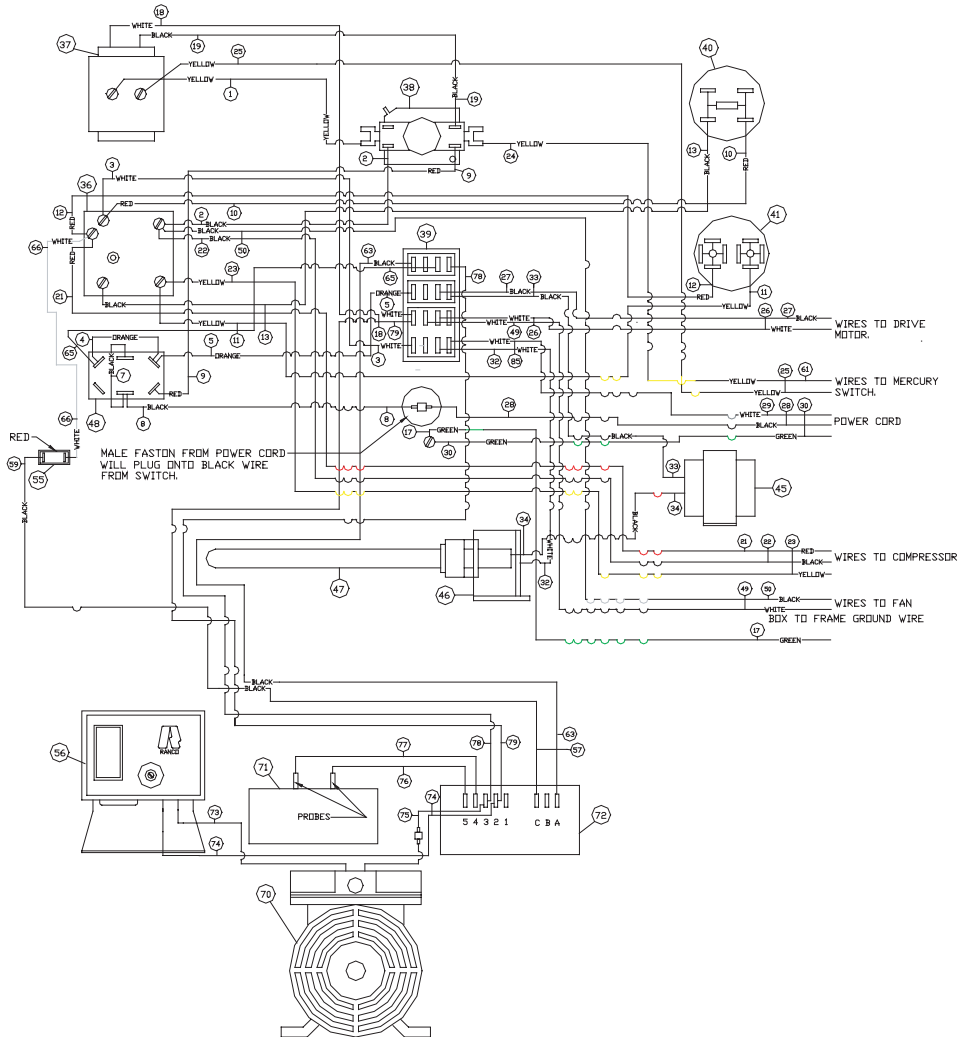

1	Yellow Wire 18 GA.	28	Black Wire from Power Cord
2	Black Wire 16 GA.	29	White Wire from Power Cord
3	White Wire 16 GA.	30	Green Wire from Power Cord
4	Orange Wire 16 GA.	32	White Solid Core 18 GA.
5	Orange Wire 16 GA.	33	Black Solid Core 18 GA.
7	Black Wire 14 GA.	34	Black Solid Core 18 GA.
8	Black Wire 14 GA.	49	White Wire 16 GA.
9	Red Wire 16 GA.	50	Black Wire 16 GA.
10	Red Wire 16 GA.	57	Blue Wire 16 GA.
11	Yellow Wire 18 GA.	61	Yellow Wire 18 GA.
12	Red Wire 16 GA.	63	Black Wire 18 GA.
13	Red Wire 16 GA.	65	Black Wire 16 GA.
14	1 White Wire 1 GA.	66	White Wire 18 GA.
17	Green Wire 16 GA.	68	Black Wire from Solenoid
18	White Wire from Transformer	69	Black Wire from Solenoid
19	Black Wire from Transformer	73	White Wire from Pump
21	Red Compressor Wire	74	White Wire 18 GA.
22	Black Compressor Wire	75	Black Wire 18 GA.
23	Yellow Compressor Wire	76	Yellow Wire 18 GA.
24	Yellow Wire 22 GA.	77	Yellow Wire 18 GA.
25	Yellow Wire 22 GA.	78	Black Wire 18 GA.
26	White Wire 16 GA.	79	White Wire 18 GA.
27	Black Wire 16 GA		

72	W0650050	Level Control Board
71	W0200901	Flow Switch
70	W0950035	Pressure Pump
56	W0650414	Low Pressure Controller
55	60033	Light, Red
48	057.0924	Switch
47	057.0043	Florescent Light Bulb
46	057.0044	Light Socket
45	057.0045	Core & Coil Ballast
44	063.0801	Tie Wraps
43	057.2068	Power Cord
42	057.2192	Low Mix Sub-Assy
41	057.0604	Run Capacitor
40	057.0603	Start Capacitor
39	057.0235	Terminal Block
38	057.0651	Time Delay Relay
37	057.2032	Transformer Sub-Assembly
36	057.0638	Compressor Relay

Refrigeration Components

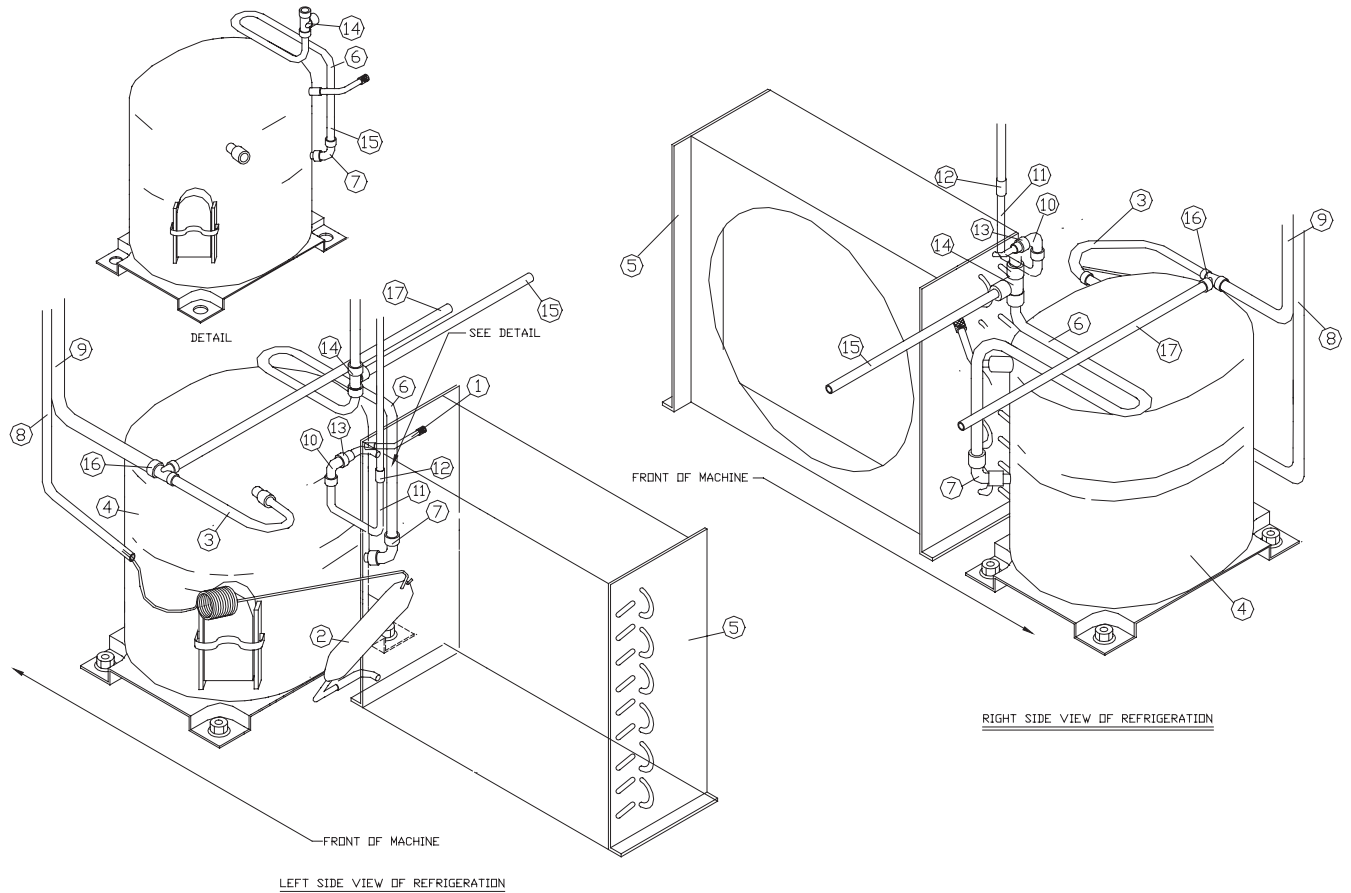

ITEM	PART #	DESCRIPTION
1	W0650501	Access Valve
2	W0200310	Drier/Cap Tube Assembly
3	W0201191	Suction Line
4	W0200123	Compressor
5	W0200256	Condenser
6	W0201009	Hot Gas Line
7	W0620112	3/8" Copper Elbow
8		Evaporator Line
9		Suction Line
10	W0620107	90 Deg. Street Elbow
11	W0201151	3/8" Cond. Connection
12	W0620103	3/8" Copper Couple
13	W0201152	5/16 x 3/8 Red/ Couple
14	W0620114	3/8" Copper Tee
15	W0201006	High Side Process Tube
16	W0620106	1/2 x 3/8 x 3/8 Copper Tee
17	W0201008	Low Side Process Tube

Refrigeration Schematic

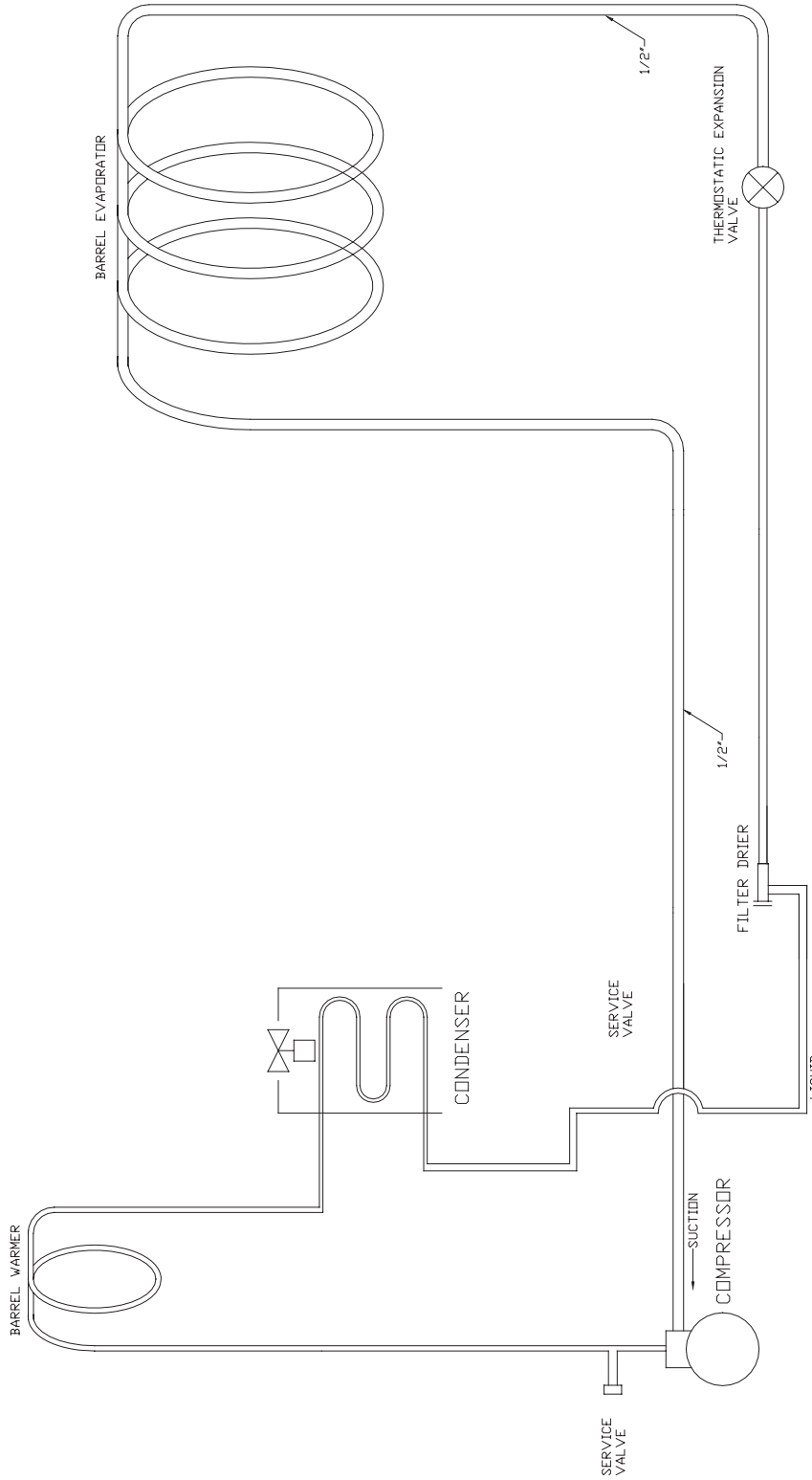

Notes



GRINDMASTER™
CORPORATION

Grindmaster® Coffee Grinders and Brewers • Espresso® Espresso Machines • Crathco® Hot Beverage Dispensers
Crathco® Cold and Frozen Beverage Dispensers • American Metal Ware® Coffee and Tea Systems
Tel (502) 425-4776 • Fax (502) 425-4664 • 1-800-695-4500
P.O. Box 35020 • Louisville, KY 40232 • USA
www.grindmaster.com • email: info@grindmaster.com